

Technical documentation
last change on: 2022-09-09

SHR

Switchable High Precision AC/DC Desktop High Voltage Power Supply

- 2 / 4 channel, 2 kV / 6kV versions
- electronically switchable polarity
- versatile 6kV-channel with switchable HV-generation modes: up to 6kV/2mA, 4kV/3mA or 2kV/4mA
- high precision / ultra low ripple and noise
- Ethernet / USB interfaces, integrated iCS2 on ARM Linux server hardware
- 4.3" TFT capacitive touch display
- comprehensive features including logging, diagrammatic display and script control
- Supported Protocols: SCPI, SNMP, EPICS, HTTP, and more



Document history

Version	Date	Major changes
2.9	2022-09-09	Improved description (iseg Communication Server, Pin and connector assignment, figures for front and back side, factory reset for SHR, add factory default in configurations, fixed documentation
2.8	2021-08-25	Improved description: Supported Protocols: SCPI, SNMP, EPICS, HTTP, and more, new front figure, new dimensions figure
2.7	2021-03-15	Improved description, Table 4: Technical data: Specifications, device description, Channel setup > INHIBIT Mode and Settings > DEVICE INFO > INHIBIT, Item code revision and customization
2.6	2021-02-02	Improved description, Settings CLEAR /RESET / BACKUP / RESTORE Save configuration and Restore configuration, HV CONNECTOR ASSIGNMENTS, CONNECTORS PART NUMBERS, CONFIGURATION ORDER GUIDE
2.5	2020-09-23	Improved description Option Lower output current
2.4	2020-07-28	Improved description ICS Server, SOAP remove
2.3	2020-05-25	Unmount USB flash memory
2.2	2020-05-07	Up- and download functions incl. ip-config.txt added
2.1	2020-04-14	improved documentation, Technical data V_{nom} ; new image Software architecture
2.0	2020-02-07	Safety Information, glossary, CDC Driver
1.3	2019-11-05	Minor fixes, Notes revised
1.2	2019-10-10	improved documentation
1.1	2018-09-20 2018-10-23	Minor fixes Notes revised
1.0	2018-03-19	Initial release

Disclaimer / Copyright

Copyright © 2022 by iseg Spezialelektronik GmbH / Germany. All Rights Reserved.

This document is under copyright of iseg Spezialelektronik GmbH, Germany. It is forbidden to copy, extract parts, duplicate for any kind of publication without a written permission of iseg Spezialelektronik GmbH. This information has been prepared for assisting operation and maintenance personnel to enable efficient use.

The information in this manual is subject to change without notice. We take no responsibility for any mistake in the document. We reserve the right to make changes in the product design without reservation and without notification to the users. We decline all responsibility for damages and injuries caused by an improper use of the device.





Safety

This section contains important security information for the installation and operation of the device. Failure to follow safety instructions and warnings can result in serious injury or death and property damage.

Safety and operating instructions must be read carefully before starting any operation.

We decline all responsibility for damages and injuries caused which may arise from improper use of our equipment.

Depiction of the safety instructions

DANGER!	
 DANGER!	<p>“Danger!” indicates a severe injury hazard. The non-observance of safety instructions marked as “Danger!” will lead to possible injury or death.</p>
WARNING!	
 WARNING!	<p>“Warning!” indicates an injury hazard. The non-observance of safety instructions marked as “Warning!” could lead to possible injury or death.</p>
CAUTION!	
 CAUTION!	<p>Advices marked as “Caution!” describe actions to avoid possible damages to property.</p>
INFORMATION	
 INFORMATION	<p>Advices marked as “Information” give important information.</p>



Read the manual.



Attention high voltage!

HIGH VOLTAGE



Important information.

Intended Use

The device may only be operated within the limits specified in the data sheet. The permissible ambient conditions (temperature, humidity) must be observed. The device is designed exclusively for the generation of high voltage as specified in the data sheet. Any other use not specified by the manufacturer is not intended. The manufacturer is not liable for any damage resulting from improper use.

Qualification of personnel

A qualified person is someone who is able to assess the work assigned to him, recognize possible dangers and take suitable safety measures on the basis of his technical training, his knowledge and experience as well as his knowledge of the relevant regulations.

General safety instructions

- Observe the valid regulations for accident prevention and environmental protection.
- Observe the safety regulations of the country in which the product is used.
- Observe the technical data and environmental conditions specified in the product documentation.
- You may only put the product into operation after it has been established that the high-voltage device complies with the country-specific regulations, safety regulations and standards of the application.
- The high-voltage power supply unit may only be installed by qualified personnel.

Important safety instructions

WARNING!



WARNING!

To avoid injury of users it is not allowed to open the unit. There are no parts which can be maintained by users inside of the unit. Opening the unit will void the warranty.

WARNING!



WARNING!

The high-voltage cable must be professionally connected to the consumer/load and the connection insulated with the appropriate dielectric strength. Do not power the consumer/load outside of its specified range.

WARNING!



WARNING!

Before connecting or disconnecting HV cables or any operation on the HV output or the application, the unit has to be switched off and discharge of residual voltage has to be finished. Depending on application residual voltages can be present for long time periods.

WARNING!



WARNING!

Do not operate the unit in wet or damp conditions.

WARNING!



WARNING!

Do not operate the unit in an explosive atmosphere.

WARNING!



WARNING!

Do not operate the unit if you suspect the unit or the connected equipment to be damaged.

WARNING!



WARNING!

The protective conductor connection must be ensured by an appropriate mains cable. Before connecting to the local power supply, check whether the nominal voltage of the devices corresponds to the mains voltage.

WARNING!



WARNING!

The mains connection is made with basic insulation and protective conductor. The device may only be operated with the protective earth conductor (PE) connected!

The protective conductor connections must be checked for proper function after installation.

WARNING!



WARNING!

Risk of death due to electric shock!

Disconnect the appliance from the mains before carrying out any work. Do not open the housing of the unit!

CAUTION!



CAUTION!

Make sure that the units an air flow through the corresponding air inlet and outlet openings is possible.

INFORMATION



INFORMATION

Please check the compatibility with the devices used.

Table of Contents

Document history	2
Disclaimer / Copyright	2
Safety	3
Depiction of the safety instructions	3
Intended Use	4
Qualification of personnel	4
General safety instructions	4
Important safety instructions	5
1 General information	9
2 Overview	10
2.1 Front side	10
2.2 Back side	11
2.3 Options	12
3 Technical data	13
4 Handling	15
4.1 Functional principle	15
4.2 Front panel	16
4.3 Channel Switches and LEDs	17
4.4 Remote Control	17
4.5 Polarity and Output-Mode selection	18
4.6 Protection Features	18
4.6.1 Hardware Limit	18
4.6.2 Safety Loop	18
4.6.3 Single channel Inhibit	19
4.7 Floating GND configuration	20
4.8 Current limitation	20
4.8.1 Constant Current Mode	20
4.8.2 KillEnable	20
4.8.3 Delayed Trip	21
4.9 SHRcontrol: Touchscreen and Remote User Interface	22
4.9.1 General UI-elements	22
Top Bar	22
Wheel	22
Context Button Bar	22
Bottom Bar	23
4.9.2 Home view	23
4.9.3 Control / Channel list view	24
4.9.4 Channel detail view	26
Channel info bar	28
CHANNEL DETAIL elements overview	28
4.9.5 Voltage / Current settings screens	29
4.9.6 Settings menu	30
4.9.7 Graph plugin	34
4.9.8 More plugins / customization	35
4.10 Factory Reset	35
5 iCS2 – iseg Communication Server	36
5.1 System description	37
5.2 Software architecture	38
5.2.1 How to connect via WiFi	39

5.2.2	How to connect via Ethernet	39
5.2.3	iCSconfig: manage hardware, service and preferences	40
5.3	Hardware	41
5.3.1	Ethernet configuration	42
5.3.2	(Re)set / ethernet configuration	43
5.3.3	WiFi configuration	43
5.4	Users / roles configuration	44
5.4.1	Access Control Lists (ACL)	44
5.4.2	SSH access	44
5.4.3	(Re)set SSH access	44
5.4.4	iCS Factory Reset Invocation	45
5.4.5	Instructions:	45
5.5	iCSservice configuration	46
5.5.1	HTTP interface	47
5.5.2	EPICS	48
5.5.3	HALservice	49
5.5.4	SNMP	49
5.5.5	Updates	50
5.5.6	Custom scripts	52
5.6	iCScontrol software overview	53
5.6.1	Left bar: Hardware Explorer	54
5.6.2	Left bar: Channel folders	54
5.6.3	Left bar: Channel profiles	54
5.6.4	Center bar: Channel list	55
5.6.5	Right bar: Device information	55
5.6.6	Right bar: Camera	55
5.6.7	Right bar: Live log	55
5.6.8	Right bar: Commands	55
6	Options	56
6.1	VCT – voltage correction by temperature	56
6.1.1	Technical data	56
6.1.2	Operation	56
6.2	IHB – BNC connectors for Single channel INHIBIT	57
6.3	IHD - Detector INHIBIT	57
6.4	L – Lower output current (HP only)	57
6.5	TC – Lower temperature coefficient (HP only)	57
7	Dimensional drawings	58
8	Connectors assignments	61
9	PIN assignments	62
9.1	Safety Loop socket	62
9.2	Inhibit	62
10	Accessories	62
11	Order guides	63
12	Appendix	64
13	Glossary	65
14	Warranty & Service	66
15	Disposal	66
16	Manufacturer contact	66

1 General information

The iseg SHR modules are standalone High Precision HV laboratory SMU – Source Measuring Unit – equipped with the finest iseg HV generation technology and iCS control system.

The SHR provides up to 4 channels, each with an independent voltage and current control and electronically reversible polarity. The 6kV channel provides a maximum versatility: with three electronically switchable HV-output modes it can supply 4mA up to voltages of 2kV, 3mA up to 4kV and 2mA up to 6kV. Alternatively the SHR can be equipped with cost efficient 2kV/6mA channels. A high quality 4.3" TFT display shows detailed information and can be controlled by capacitive touch. All comprehensive features like logging, graphical display and customer specific plugins are also available by the precise jog-wheel and buttons.

2 Overview

2.1 Front side

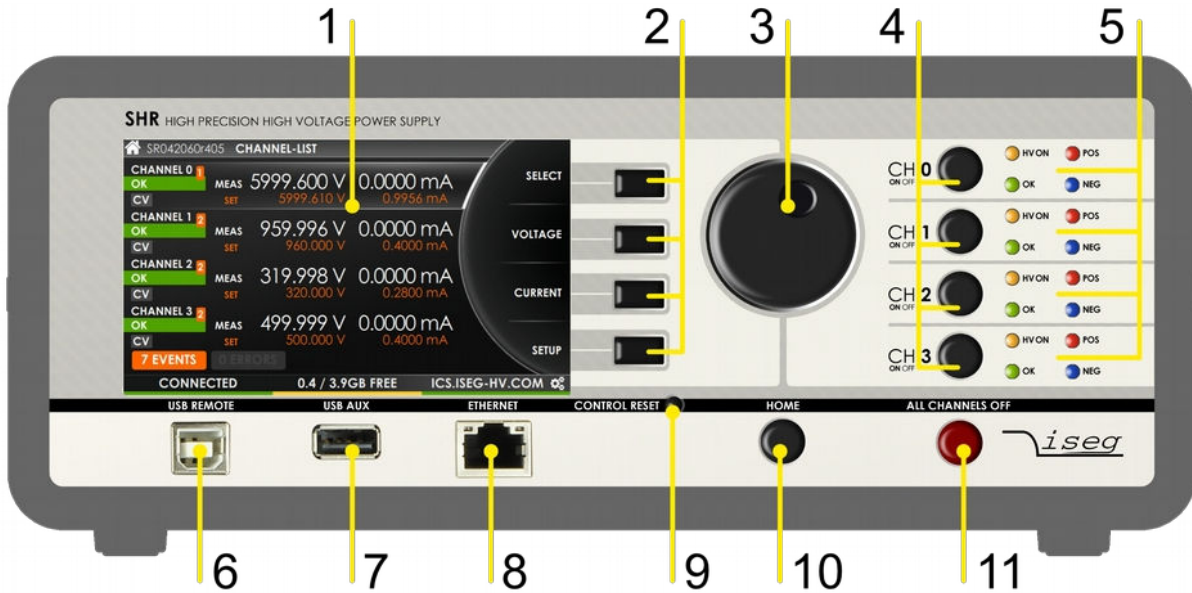

Figure 1: 4 channel SHR Front

Number	Description	Description	Detailed explanation in chapter
[1]	Display	Display data	4.1 Functional principle, 4.2 Front panel, 4.9 SHRcontrol: Touchscreen and Remote User Interface, 4.9.3 Control / Channel list view, 4.9.6 Settings menu
[2]	4 Function Buttons	Context sensitive buttons	4.1 Functional principle, 4.2 Front panel, 4.9 SHRcontrol: Touchscreen and Remote User Interface, 4.9.3 Control / Channel list view
[3]	Rotary and Push button	Selection/change of Display data	4.1 Functional principle, 4.2 Front panel,
[4]	Channel ON/OFF	Channel ON/OFF	4.1 Functional principle, 4.3 Channel Switches and LEDs
[5]	Status LEDs per Channel	Channel status indication	4.1 Functional principle, 4.3 Channel Switches and LEDs
[6]	USB REMOTE	Interface	4.1 Functional principle, 4.4 Remote Control
[7]	USB AUX	Interface	4.1 Functional principle, 4.9 SHRcontrol: Touchscreen and Remote User Interface
[8]	ETHERNET	Interface	4.1 Functional principle, 4.4 Remote Control
[9]	CONTROL RESET	Reset front panel controller unit	4.1 Functional principle, 4.2 Front panel
[10]	HOME	Changes to Home screen	4.1 Functional principle, 4.2 Front panel
[11]	ALL CHANNELS OFF	Switch off all high-voltage channels without ramp	4.1 Functional principle, 4.2 Front panel

Table 1: Front elements

2.2 Back side

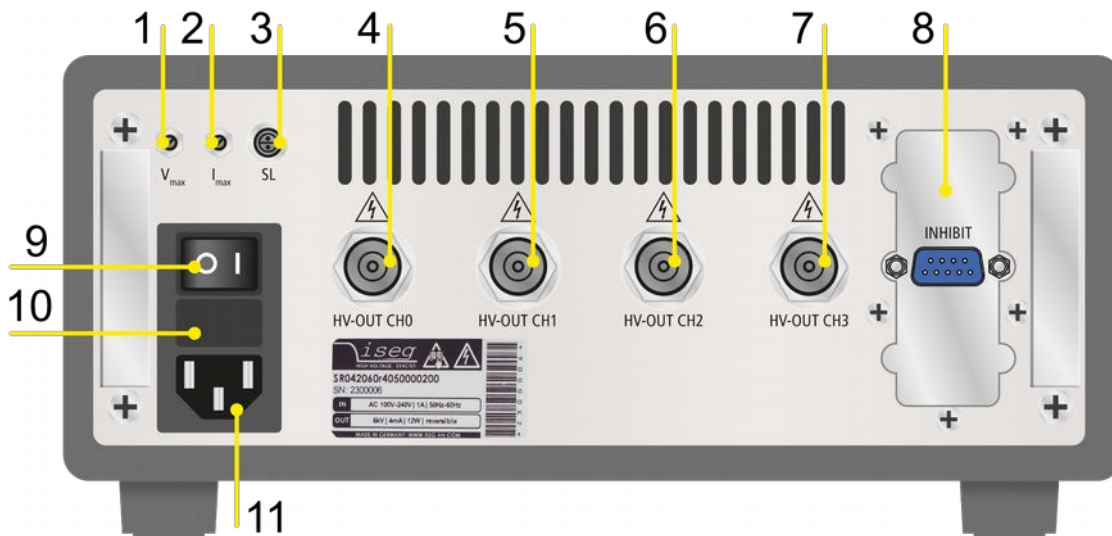

Figure 2: 4 channel SHR Back side

Number	Description	Detailed explanation in chapter
[1]	V _{MAX}	Voltage hardware limit 4.1 Functional principle, 4.6.1 Hardware Limit
[2]	I _{MAX}	Current hardware limit 4.1 Functional principle, 4.6.1 Hardware Limit
[3]	SL	Safety Loop Connector 4.1 Functional principle, 4.6.2 Safety Loop
[4]	HV-OUT CH0	Output channel 0 8 Connectors assignments
[5]	HV-OUT CH1	Output channel 1 8 Connectors assignments
[6]	HV-OUT CH2 ⁽¹⁾	Output channel 2 8 Connectors assignments
[7]	HV-OUT CH3 ⁽¹⁾	Output channel 3 8 Connectors assignments
[8]	Options	Options area 2.3 Options, 6 Options
[9]	Mains Switch	Mains switch
[10]	Fuse	Fuse Holder 3 Technical data
[11]	Mains input	AC Power connector 3 Technical data

Notes:
¹⁾ - only 4ch Type

Table 2: Back elements

2.3 Options

	2 channels	4 channels
IHB / IHD Channel 0 Channel 1 Channel 2 ⁽¹⁾ Channel 3 ⁽¹⁾		
VCT Channel 0 Channel 1 Channel 2 ⁽¹⁾ Channel 3 ⁽¹⁾		
Inhibit The assignment of the connections is described in 8 Connectors assignments		
Notes: ⁽¹⁾ - only 4ch Type		

Table 3: option variants

3 Technical data

SPECIFICATIONS	SHR Standard	SHR High Precision
Polarity	Electronically switchable	
Ripple and noise (f > 10 Hz)	< 10 mV _{p-p}	< 2 - 3 mV _{p-p}
Ripple and noise (f > 1 kHz)	< 3 mV _{p-p}	< 2 mV _{p-p}
Ripple and noise (10 Hz – 0.1Hz)		< 5 - 10 mV _{p-p}
Stability – [$\Delta V_{out} / \Delta R_{load}$]	$2 \cdot 10^{-4} \cdot V_{mode}$	$1 \cdot 10^{-4} \cdot V_{mode}$
Temperature coefficient	50 ppm/K	30 ppm/K 10 ppm/K (option TC)
Resolution voltage setting	$2 \cdot 10^{-6} \cdot V_{nom}$	
Resolution current setting	$2 \cdot 10^{-6} \cdot I_{nom}$	
Resolution voltage measurement ⁽¹⁾	$2 \cdot 10^{-6} \cdot V_{nom}$	$1 \cdot 10^{-6} \cdot V_{nom}$
Resolution current measurement - full range ⁽¹⁾	$2 \cdot 10^{-6} \cdot I_{nom}$	$1 \cdot 10^{-6} \cdot I_{nom}$
Resolution current measurement [$I_{out} < 20 \mu A$] (2nd range) ^{(1) (4)}	n/a	50 pA
Accuracy voltage measurement	$\pm (0.01 \% \cdot V_{out} + 0.02 \% \cdot V_{nom})$	$\pm (0.01 \% \cdot V_{out} + 0.01 \% \cdot V_{nom})$
Accuracy current measurement - full range	$\pm (0.01 \% \cdot I_{out} + 0.02 \% \cdot I_{nom})$	$\pm (0.01 \% \cdot I_{out} + 0.01 \% \cdot I_{nom})$
Accuracy current measurement (2nd range) ⁽⁴⁾	n/a	$\pm (0.01 \% \cdot I_{out} + 4 \text{ nA})$
Measurement accuracy - The measurement accuracy is guaranteed in the range $1\% \cdot V_{mode} < V_{out} < V_{mode}$ and for 1 year		
Sample rates (SPS)	5, 10, 25, 50, 60, 100, 500 ⁽²⁾	5, 10, 25, 50 ⁽²⁾ , 60, 100, 500
Digital filter averages	1, 16, 64 ⁽²⁾ , 256, 512, 1024	
Hardware limits	Potentiometer per module [V_{max} / I_{max}]; relative to V_{nom} / I_{nom}	
Voltage ramp	$1 \cdot 10^{-6} \cdot V_{nom}/s$ up to $0.2 \cdot V_{nom}/s$	
Rated AC mains input	100 – 240 VAC, 1.5 A max, 50/60 Hz over voltage category II	
Fuse	2x T 1.6A L 250V / microfuse 5mm x 20mm, 250V / 1.6AT	
AC power connector	socket according IEC 60320 C13	
AC power cord	Power cord must correspond to requirements of IEC 60799	
HV connector	SHV, Figure 29	
Safety Loop connector	Lemo 2pole, Figure 34	
Interfaces	Ethernet, USB(A) 2.0 (Host: Wifi, Logging, Webcam), USB(B) (remote control)	
Protection	INHIBIT, Safety loop, short circuit, overload, hardware V/I limits (ATTENTION: there is only one short circuit or arc per second allowed!)	
Case	desktop case	
Weight	5 – 5,5 kg ⁽³⁾	
Dimensions (L/W/H)	331/257/103 mm	

SPECIFICATIONS	SHR Standard	SHR High Precision
Operating temperature		0 – 40 °C
Storage temperature		-20 – 60 °C
Operating Altitude		0 – 2000 m
Further environmental conditions	equipment is for use in closed environment only, relative humidity 20% to 90% (no condensation), maximum Pollution degree level 2	
Notes: ¹⁾ The resolution of measurable values depends on the settings of the sampling rate and the digital filter! ²⁾ Factory settings ³⁾ depending on equipment ⁴⁾ not available with Option L		

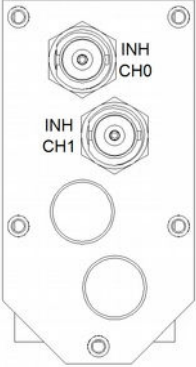
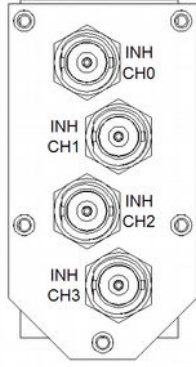
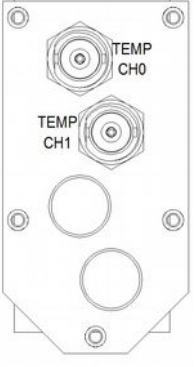
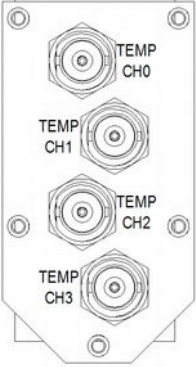
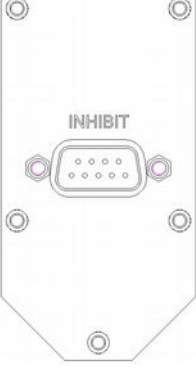
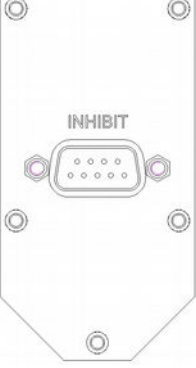
Table 4: Technical data: Specifications

CONFIGURATIONS SHR										
Type	Ch	Precision	V _{nom}	I _{nom}	Ripple (mV _{p-p})			HV output mode (V _{mode} / I _{mode})	Item Code	Options
					>1kHz	10Hz-1kHz	0.1Hz-10Hz			
SHR 20 20	2	Standard	2000 V	6 mA	3	10	n/a	2 kV / 6 mA ⁽¹⁾	SR020020r605oooccrk	VCT, IHB, IHD
SHR 20 60	2	Standard	6000 V	4 mA	3	10	n/a	6 kV / 2mA 4kV / 3mA 2kV / 4mA ⁽¹⁾	SR020060r405oooccrk	VCT, IHB, IHD
SHR 40 20	4	Standard	2000 V	6 mA	3	10	n/a	2 kV / 6 mA ⁽¹⁾	SR040020r605oooccrk	VCT, IHB, IHD
SHR 40 60	4	Standard	6000 V	4 mA	3	10	n/a	6 kV / 2mA 4kV / 3mA 2kV / 4mA ⁽¹⁾	SR040060r405oooccrk	VCT, IHB, IHD
SHR 22 20	2	High	2000 V	6 mA	2	2	5	2 kV / 6 mA ⁽¹⁾	SR022020r605oooccrk	VCT, IHB, IHD, TC, L
SHR 22 60	2	High	6000 V	4 mA	2	3	10	6 kV / 2mA 4kV / 3mA 2kV / 4mA ⁽¹⁾	SR022060r405oooccrk	VCT, IHB, IHD, TC, L
SHR 42 20	4	High	2000 V	6 mA	2	2	5	2 kV / 6 mA ⁽¹⁾	SR042020r605oooccrk	VCT, IHB, IHD, TC, L
SHR 42 60	4	High	6000 V	4 mA	2	3	10	6 kV / 2mA 4kV / 3mA 2kV / 4mA ⁽¹⁾	SR042060r405oooccrk	VCT, IHB, IHD, TC, L
Notes: replacement characters: o – options, c – connector, r – revision, k – customization ¹⁾ - Factory setting values										

Table 5: Technical data: Configurations

OPTIONS / ORDER INFO	INFO	EXAMPLE	ITEM CODE HEX CODE
SINGLE CHANNEL INHIBIT – BNC connectors	IHB		400
DETECTOR INHIBIT (ORTEC/CANBERRA)	IHD		800
VOLTAGE CORRECTION by TEMPERATURE	VCT		008
LOWER TEMPERATURE COEFFICIENT	TC		004
LOWER OUTPUT CURRENT	L (I _{nom} = 100 µA)		-

Table 6: Technical data: Options and order information

4 Handling

CAUTION!



CAUTION!

The device is not designed to operate as a current sink.
Never apply external voltages of opposite polarity to the selected one or with values greater than the maximum value of the selected output mode. This can damage the module.

4.1 Functional principle

The SHR module combines a very precise and powerful high voltage supply unit and an intelligent front panel controller.

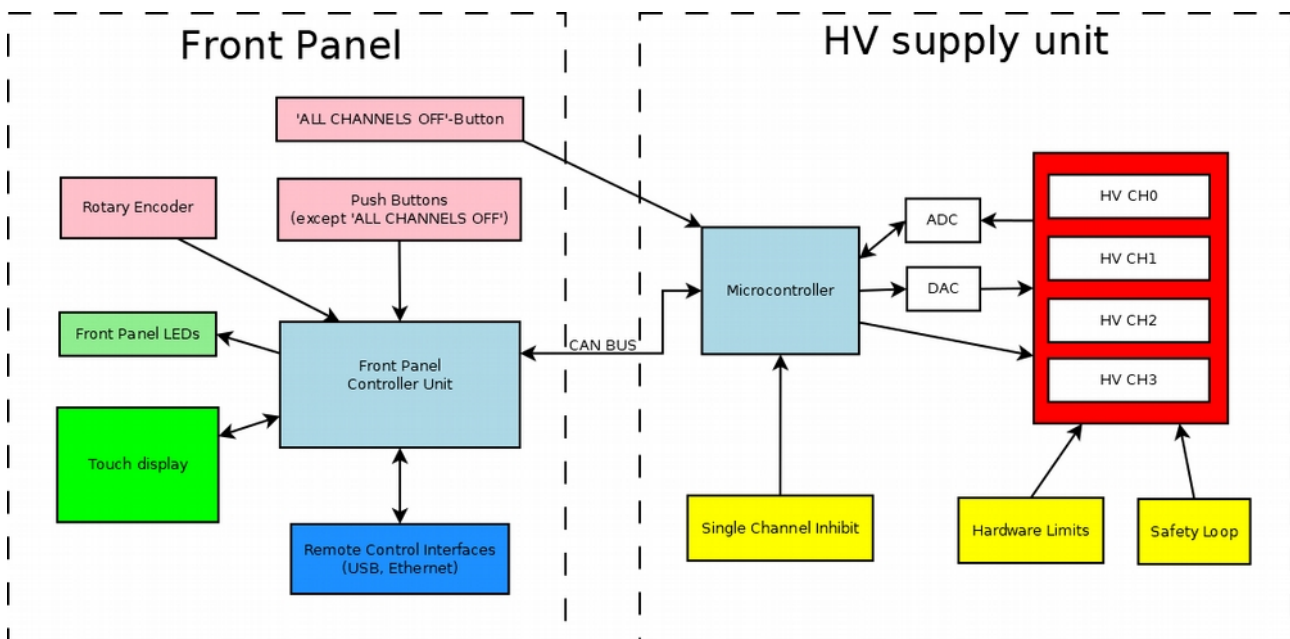

Figure 3

The high voltage supply unit runs independently and controls and monitors all parameters and conditions for high voltage generation. This includes set values, ramping, voltage and current measurements, hardware control and status information, etc.. Also the protection feature safety loop, hardware limits and single channel inhibit act directly on the HV supply unit.

The front panel controller, a computer module with an embedded Linux-Server system, serves the front panel operating elements (touch display, status LEDs, push buttons except 'ALL CHANNELS OFF' and the rotary encoder) and provides remote control interfaces. It also provides the iseg Communication Server (ICS), which comes with an extensive preconfigured set of software services (see chapter „5 iCS2 – iseg Communication Server“). The front panel controller is connected to the HV supply unit via an internal CAN bus to obtain the operation data and send control commands.

The USB interface is realized with an USB-B connector at the front panel. The used chipset is CDC-ACM, witch operates as a virtual serial port in the PC, and can be used with every program that supports serial ports. Most often a driver installation (see 12 Appendix) is necessary before the virtual serial port can be used, though. The CDC-ACM driver can be downloaded from the SHR to a connected USB Flash memory by Save USB drivers of the settings menu.

4.2 Front panel

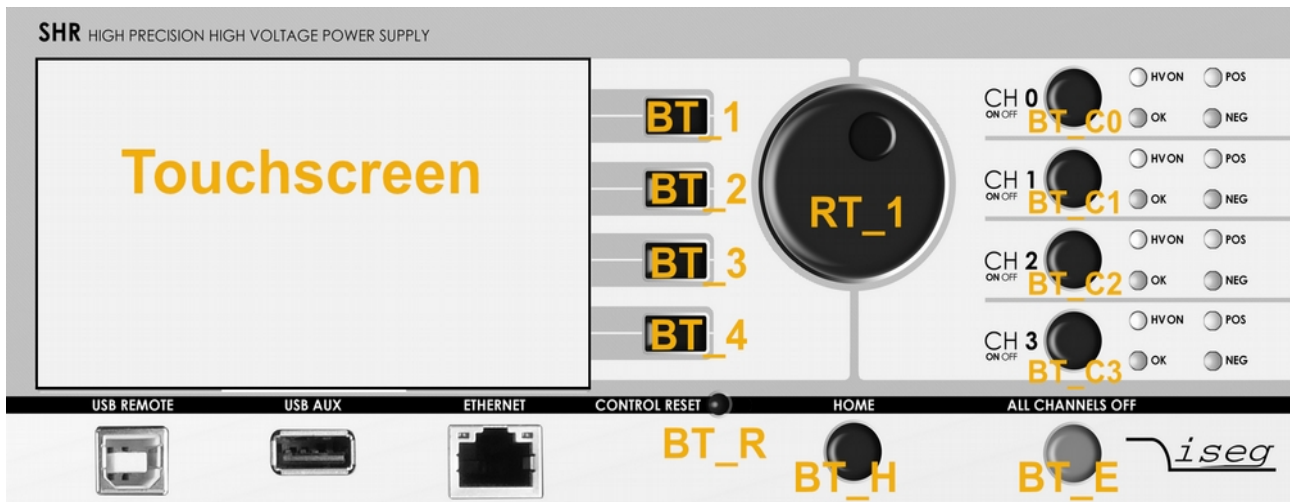

Figure 4: front panel SHR, 4 channels

The front panel of the SHR owns the following control elements:

Frontpanel	480px • 272px 4 Zoll capacitive touch screen interface
RT1	Rotary button
BT_1 to BT_4	4 context sensitive pushbuttons, display shows corresponding action (see "context button bar", chapter 4.9.1 General UI-elements)
BT_H	Home action push button - opens Home menu
BT_C0 to BT_C3 ¹	Channel ON/OFF push buttons
BT_E	ALL CHANNELS OFF push button - immediatly shuts down all channels
BT_R	Reset for the front panel controller

Table 7

Note: The **CONTROL RESET (BT_R)** button causes a reboot of the front panel controller. The high voltage generation is not affected by this. If pushed, all HV-channels will remain active with their previously specified polarity, set values, running and ramping states, trip parameters etc.. During the following reboot (approx. 10-12s) there will be no information on the display and the channel LEDs do not show the current running status, i.e. toggling of OK, HV ON or polarity LEDs do not indicate a change in HV generation. Also front panel and remote control is interrupted. Once reboot is finished the display/LED information is recovered and remote control services are restarted.

To shut down high voltage during the reboot process the ALL CHANNELS OFF button can be used. This button acts directly on the HV-channels, independently of the front panel controller.

CAUTION!	
 CAUTION!	If CONTROL RESET (BT_R) is pushed during operation with high voltage generation all channels will keep their running status. During reboot time of the controller the display and channel LEDs do not show the current running status (i.e. HV generation might be active although the corresponding HV ON LED is not illuminated). Front panel and remote control is not available during this time.

1 2 channel SHR version has only BT_C0 and BT_C1

4.3 Channel Switches and LEDs

The front panel of the SHR device is equipped for each channel with a “On/Off” switch (BT_C0 to BT_C3, see chapter 4.2 Front panel) to turn the channel on and off, two status LEDs (“OK” and “HV ON”) and two LEDs (“POS” and “NEG”) to indicate the selected polarity.

The green LED “OK” signals the general condition of the channel and the yellow LED “HV ON” signals measured output voltage at the corresponding channel or is flashing shortly every time the user presses the corresponding “On/Off” switch.

Following behaviors are possible:

LED “OK”	LED “HV ON”	Meaning
not illuminated	not illuminated	An error event occurred, the channel cannot be switched on.
not illuminated	illuminated	An error occurred but there is still a measured voltage at the channel.
illuminated	not illuminated	The channel is switched off and can be turned on.
illuminated	illuminated	The channel is turned on and there is output voltage at the channel.
	flashing	The channel is ramping up or down.

Table 8: LED Status information

CAUTION!



During the boot-up time of the SHR device the channel LEDs may not represent the status of module. Please wait until boot-up is finished (max. 10-12s) to get current information.

CAUTION!

4.4 Remote Control

The SHR devices offer two remote control interfaces: USB remote and Ethernet.

With the USB remote connector, one SHR can be controlled with the iseg SCPI instruction set. Available control applications are isegControl2, iseg Terminal and iseg SCPI Control. Please consider the “SCPI Programmers-Guide” (see chapter 12 Appendix) for further details.

The SHR Ethernet interface is supplied by an iseg iCS2 onboard Linux based single board computer. Using Ethernet a various set of services is offered, like webbrowser based configuration, monitoring and control, by isegControl2 or to be integrated into systems by EPICS, SNMP, OPC-UA and more. The remote configuration and usage of the iCS system is described in the chapter „5 iCS2 – iseg Communication Server“.

4.5 Polarity and Output-Mode selection

Configuration change (permanent):

For all channels of SHR devices the polarity can be electronically switched. This can be done as permanent configuration of the device via front panel SHRcontrol (*HOME* → *SETTINGS* → *HARDWARE SETUP* → *CHANNEL SETUP* → *CHANNEL x* → *POLARITY* (see chapter 4.9.6 Settings menu) or by iCSconfig (see chapter iCS2).

Modules with $V_{nom} = 6\text{kV}$ (except option **L**) also provide switchable HV-output modes which allow to switch the nominal values of a channel between 2kV/4mA, 4kV/3mA and 6kV/2mA. This can be done via the front panel (*HOME* → *SETTINGS* → *HARDWARE SETUP* → *CHANNEL SETUP* → *CHANNEL x* → *POLARITY*, see chapter 4.9.6 Settings menu) or by iCSconfig (see chapter iCS2).

Switching the polarity or output mode is only allowed if the corresponding channel is switched off and discharged below $0.002 \cdot V_{nom}$. The module blocks all switching attempts if these conditions are not satisfied.

Change during operation:

CAUTION!



CAUTION!

The device is not designed to operate as a current sink.
Never apply external voltages of opposite polarity to the selected one or with values greater than the maximum value of the selected output mode. This can damage the module.

The second way to change the polarity and output mode is during operation by use of any API (using iCSservice, isegHALservice, SNMP, EPICS, OPC-UA). Therefore the corresponding channel data objects can be addressed for change (e.g. Setup.Polarity, Setup.OutputMode on iCSservice → see items.xml definition (iCS2 → iCSconfig → iCSservice)).

4.6 Protection Features

4.6.1 Hardware Limit

The maximum output voltage for all channels (hardware voltage limit) is defined through the position of the corresponding potentiometer V_{max} (see number 1 on Figure 2: 4 channel SHR Back side). The maximum output current for all channels (hardware current limit) is defined through the position of the corresponding potentiometer I_{max} (see number 2 on Figure 2: 4 channel SHR Back side). Both potentiometers are located on the rear panel (chapter 2.2 Back side). The greatest possible set value for voltage and current is given by $V_{max} - 2\%$ and $I_{max} - 2\%$, respectively. The per cental values always refer to the nominal values of the channel, V_{nom} and I_{nom} . E.g. for a 6kV/4mA module the reference values are 6kV and 4mA, independent of the selected output mode.

The output voltage and current are limited to the specified value. If the maximum voltage or current of the selected output mode (V_{mode} or I_{mode}) is below this limit, this will further limit the output.

If a limit is reached or exceeded in any channel the corresponding green LED on the front panel turns off (see chapter 2.1 Front side).

4.6.2 Safety Loop

A safety loop can be implemented via the safety loop socket (SL, Figure 34) on the rear panel (see chapter 2.2 Back side).

An internal current source drives approx. 5 mA with a maximum voltage drop of 18V between the connector pins. High voltage can only be generated if the safety loop is closed.

If the safety loop is opened during the operation, the output voltages are shut off without ramp. Furthermore, the corresponding bits in the „ModuleStatus“ and „ModuleEventStatus“ registers are set (see “CAN EDCP Programmers-Guide“ in 12 Appendix). After closing the loop again, the „ModuleEventStatus“ register must be reset to turn the channels on again. The safety loop can be deactivated by placing the provided jumper on the connector.

4.6.3 Single channel Inhibit

INFORMATION



INFORMATION

INHIBIT is an external signal, that switches off the high voltage for the device or a specific channel.

Note: This section only describes the standard single channel Inhibit (no Inhibit option or option IHB). For option IHD see the corresponding subsection in chapter 6 Options. For modules with option VCT single channel Inhibit is not available.

Modules with none of the options IHB, IHD or VCT are equipped with a Sub-D connector on the backplane of the module with the pin assignment find in chapter 9.2 Inhibit.

Modules with option IHB are equipped with a BNC-connector for each channel. The signal GND is identical with the module GND (HV-return). The INHIBIT signals are TTL-level, the signal logic and default states can be configured. The following settings are possible:

Case 1 – IU

INHIBIT signal logic:	LOW-active	(LOW → HV-generation stopped)
default state:	HIGH	(internal pull-up resistor applied)
open INHIBIT signal input:	HV enabled	

Case 2 – ID

INHIBIT signal logic:	LOW-active	(LOW → HV-generation stopped)
default state:	LOW	(internal pull-down resistor applied)
open INHIBIT signal input:	HV disabled	

Case 3 – NIU

INHIBIT signal logic:	HIGH-active	(HIGH → HV-generation stopped)
default state:	HIGH (internal pull-up resistor applied)	
open INHIBIT signal input:	HV disabled	

Case 4 – NID

INHIBIT signal logic:	HIGH-active	(HIGH → HV-generation stopped)
default state:	LOW	(internal pull-down resistor applied)
open INHIBIT signal input:	HV enabled	

The INHIBIT signal must be applied for at least 100 ms to guarantee a detection. If an Inhibit signal is detected, the channel status bit 'is External Inhibit' and the channel event status bit 'Event External Inhibit' are set. One of the following reactions to this signal can be programmed:

- No Action (default)
- Turn off the channel with ramp
- Shut down the channel without ramp
- Shut down all channels without ramp

When the INHIBIT is no longer active, the Inhibit flag must be reset before the voltage can be switched on again.

4.7 Floating GND configuration

The SHR module is a module with Common Floating Ground (CFG). All HV-channels have a common return potential (module GND), which is galvanically isolated from PE. The module housing is connected to PE. A protection circuit prevents differences between the module GND and PE potentials of more than 39V.

4.8 Current limitation

4.8.1 Constant Current Mode

The Constant Current Mode (CC) is the default response on an increased output current. If the output current would exceed the set current (I_{set}) at the specified set voltage (V_{set}) the channel operates as a constant current source at I_{set} .

For modules with one current measurement range the module can operate in CC Mode for I_{set} values in the range $I_{nom} \geq I_{set} \geq 5E-04 \cdot I_{nom}$. Although the modules accepts smaller values I_{set} , the CC Mode can only operate down to the given limitation. Smaller set value will only affect the functions **KillEnable** and **Delayed trip**, described below.

Modules with two current measurement ranges can operate in CC Mode with I_{set} values down to 200 nA. The following limitations must be considered when operating a channel with I_{set} values in the lower current measurement range (i.e. typically $<20\mu A$):

- If $I_{set} < 20\mu A$ the maximum voltage ramp speed is limited to 1 % of V_{nom} . If the load has a significant capacitance it might be necessary to further reduce the voltage ramp speed to avoid ramp instabilities.
- While a channel is operating in CC Mode it is not possible to switch between the two current measurement ranges, i.e. the set current cannot be changed from a value $> 20 \mu A$ to a value $< 20 \mu A$ or vice versa. To change the set current across the measurement range boundary the channel must stop operation in CC mode (i.e. by switching off the channel or reducing the voltage such, that it operates in Constant Voltage Mode (CV)).

4.8.2 KillEnable

The function KillEnable forces the shut down of a channel at the fastest hardware response time (smaller than 1 ms) if a specified trip current is exceeded. If *KillEnable* is active the value of the set current (I_{set}) defines the trip current. An approach or exceedance of this current (detected by a hardware signal) will immediately shut off the channel without ramp. However, the actual discharge time strongly depends on the connected load.

The following limitations must be considered if the function KillEnable is activated:

- Maximum voltage ramp speed is limited to 1 % of V_{nom} . To avoid unintended current trips during ramps it might be necessary to further reduce the ramp speed for very small trip currents or capacitive loads. Alternatively KillEnable can be activated only after the completion of the ramp.
- The minimum trip currents for a hardware detection is $5E-04 \cdot I_{nom}$ for modules with one current measurement range and 200 nA for modules with two current measurement ranges. It is possible to specify smaller trip values, however there is no hardware current limitation below the hardware detection limits. Also, the response time on a trip that does not triggers the hardware detection can be up to 1s.
- Modules with two current measurement ranges do not change the current measurement range if KillEnable is active. The channel remains in the high measurement range if $I_{set} > 20\mu A$ and in the low measurement range for $I_{set} \leq 20\mu A$. It is not possible to switch the current measurement while a channel is switched on and KillEnable is active, i.e. the set current cannot be changed from a value $> 20 \mu A$ to a value $< 20 \mu A$ or vice versa. If it is intended to switch the current measurement range, the channel must be switched off or KillEnable must be deactivated for altering the current set value.

4.8.3 Delayed Trip

The function "*Delayed Trip*" provides a user-configurable, time-delayed response to an increased output current (I_{out}) higher than the set current (I_{set}). The response to this kind of event can be, for example, to ramp down the channel with the programmed ramp. A detailed description for the configuration can be found in the "CAN EDCP Programmers-Guide" in chapter 12 Appendix.

By a programmable timeout with one millisecond resolution, the trip can be delayed up to four seconds. During this time, the output current is limited to the value of I_{set} (constant current mode).

The hardware regulation signals, constant voltage (CV) or constant current (CC), are sampled every millisecond by the microprocessor. Once the constant current mode is active, the programmed timeout counter is decremented. If the HV channel returns to constant voltage mode before timeout (i.e. $I_{out} < I_{set}$), the counter will be reset. So this process can be restarted if the current rises again.

To guarantee a sufficient resolution for the current set values, a nominal current adequate to the application should be selected. iseg offers HV modules with nominal currents reduced to 100 μ A in all voltage classes. These are designated e.g. for semiconductor detectors, which only require a few microampere operating current.

INFORMATION



INFORMATION

An activated KillEnable feature disables the Delayed Trip function.

4.9 SHRcontrol: Touchscreen and Remote User Interface

4.9.1 General UI-elements



Figure 5: SHRcontrol channel list view

The SHRcontrol user interface is available directly as HMI on the front panel of the SHR High Voltage Power supply. It is controllable by the hardware buttons and the rotary button. SHRcontrol is also available as desktop applications for Windows, Linux and Mac, where additional features are available.

Top Bar



Figure 6: Top bar

The Topbar indicates the following entries:

- the model number of the current device (or remotely the currently connected device). The home icon indicates that this area can also be used to reach the Home Screen when in remote operation
- the navigation information indicates the current view or menu page path that is displayed

Wheel

- on the right side of the user interface the half of a wheel is displayed. It indicates rotation of the rotary wheel. When using the touch interface it can be swiped to change values or select items in lists. Remotely the area over the wheel activates the mouse scroll wheel. So when the mouse pointer is over the wheel area, the scroll wheel simulates rotation of the hardware rotary.



Figure 7: Wheel

Context Button Bar

On top of the wheel 4 context buttons are available for view specific actions. They can be clicked using the corresponding hardware buttons on the SHR or remotely by clicking directly. A context button can also be set as a toggable switch. In this case it is highlighted by a background color.

Bottom Bar



Figure 8: Bottom Bar

The bar on the bottom of the user interface shows hardware related information of the SHR device. The color of each panel represents a status:

GREEN	Status of hardware or connection is OK
YELLOW	User ATTENTION is needed for hardware or connection
RED	ERROR occurred, may cause incorrect operation
GREY	Hardware or connection is INACTIVE or DISABLED

Table 9

The left panel indicates the state of the remote USB connection. The middle panel shows information about the currently connected USB AUX device, such as information of a USB flash memory or the connected lab surveillance camera. The middle panel can be used as button to call USB configuration e.g. to unmount an USB flash device. The right panel shows the current IP address of the SHR to easily find connection to iCS using a web browser or to be entered in a SHRcontrol remote desktop application. When used remotely, the currently configured IP address of the SHR that is connected in this panel. In remote mode, SHRcontrol can be clicked to open the connection menu directly. This is indicated also by the menu icon (cogwheels).

4.9.2 Home view



Figure 9 - SHRcontrol HOME VIEW

The HOME VIEW shows all available APPS of SHRcontrol. Use rotary or touchscreen to select and entry and start by clicking SELECT using BT_1 (see chapter 4.2 Front panel). The following VIEWS / PLUGINS are available

CONTROL	Control and monitor device and channels Views: CHANNEL-LIST, CHANNEL-DETAILS
GRAPH	Graphical monitoring of channels with various functions
SETTINGS	Hard- and software configuration

Table 10

4.9.3 Control / Channel list view

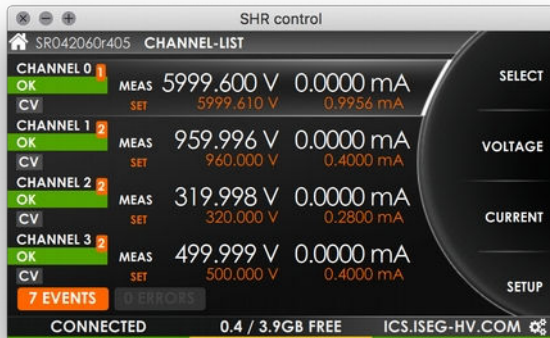

Figure 10 - SHRcontrol CHANNELLIST VIEW

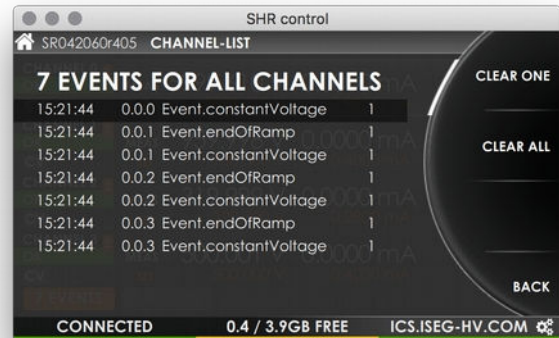

Figure 11 - SHRcontrol CHANNELLIST VIEW with EVENT LIST enabled

The channel list displays important information of all four SHR high voltage channels at a glance. By turning the rotary or using the touch interface it is possible to select a channel which is then highlighted. Now the following actions are available:

- Press button **"SELECT"** to change to the channel detail view
- Press **"VOLTAGE"** to change to voltage related settings of the selected channel
- Press **"CURRENT"** to change to current related settings of the selected channel
- Press **"SETUP"** to change directly to the channel settings page in the menu of the selected channel

Additional touchscreen / remote functions

Display Events and Errors

- One Channel: Click on an error or event badge on the upper right of a channel entry of the channel list
- All Channels and device: Click on on the event / error badge on the bottom of the screen (here „7 EVENTS“, see Figure 10 - SHRcontrol CHANNELLIST VIEW)

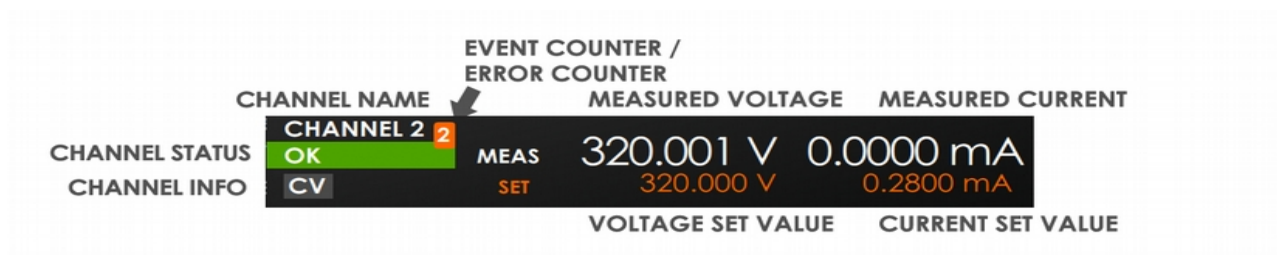

Figure 12: CHANNEL-LIST ENTRY

Each channel is represented as list element. This list element contains of the following elements:

ELEMENT	DESCRIPTION
CHANNEL NAME	Channel number
CHANNEL STATUS	GREEN: OK YELLOW: Channel is RAMPING RED: ERROR occurred GRAY: channel is OFF Remote usage: CLICK on CHANNEL STATUS to switch channel ON or OFF
CHANNEL INFO	Displays indicators of Channel properties: CV: constant voltage mode CC: constant current mode TRIP: current trip is active VLIM: voltage limit is exceeded ILIM: current limit is exceeded INH: external INHIBIT is active EMERGENCY: emergency mode active
EVENT COUNTER / ERROR COUNTER	Indicates the number of errors (RED) or events (ORANGE) occurred Remote and touch usage: CLICK on badge to open ERROR or EVENT LIST overlay
MEASURED VOLTAGE	Measured voltage of this channel using the configured unit and precision (see MENU / HARDWARE / DISPLAY for configuration)
MEASURED CURRENT	Measured current of this channel using the configured unit and precision (see MENU / HARDWARE / DISPLAY for configuration)
VOLTAGE SET VALUE	Voltage Set value in configured unit
CURRENT SET VALUE	Current Set value in configured unit

Table 11

4.9.4 Channel detail view

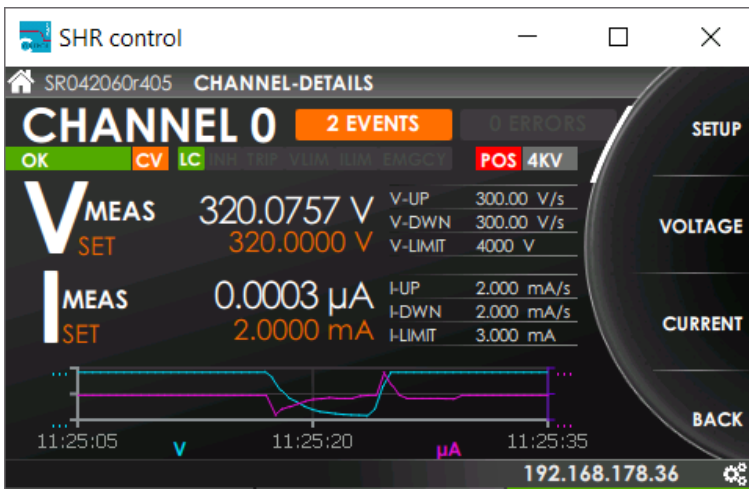

Figure 13: - SHRcontrol CHANNEL-DETAIL VIEW

The CHANNEL DETAIL VIEW shows information of the selected channel. In this context the following actions are available:

Press "SETUP" to get directly to CHANNEL-SETUP menu in SETTINGS

Press "VOLTAGE" to change to voltage related settings of the selected channel

Press "CURRENT" to change to current related settings of the selected channel

Press button "BACK" to change back to CHANNEL-LIST view

CHANNEL DETAIL VIEW user interface elements:

VOLTAGE SECTION			
VMEAS	Shows measured voltage shown in the configured precision and unit (see SETTINGS , see chapter 4.9.6 Settings menu)	V-UP	Voltage Up-Ramp: configured speed of voltage changes to more voltage (absolute value) in Voltage Control (VC) mode
VSET	Shows set voltage of shown channel in the configured precision and unit (see SETTINGS , see chapter 4.9.6 Settings menu)	V-DOWN	Voltage Down-Ramp: configured speed of voltage changes to less voltage (absolute value) in Voltage Control (VC) mode
		V-LIMIT	Voltage limit: Depends on the configured Output mode (see SETTINGS) or the modules hardware limit (see section Hardware limits). The smaller value will be effective.

Table 12

CURRENT SECTION			
IMEAS	Shows measured current shown in the configured precision and unit (see SETTINGS , see chapter 4.9.6 Settings menu)	I-UP	Current Up-Ramp: configured speed of current changes to more current, in Current Control (CC) mode.
ISET	Shows set current of shown channel in the configured precision and unit (see SETTINGS , see chapter 4.9.6 Settings menu)	I-DOWN	Voltage Down-Ramp: configured speed of voltage changes to less voltage (absolute value) in Current Control (CC) mode.
		I-LIMIT	Current limit: Depends on the configured Output mode (see SETTINGS) or the modules hardware limit (see section Hardware limits). The smaller value will be effective.

Table 13

The graph shows the voltage (cyan) and current (purple) flows of the last 30 seconds. The value axes automatically adjust their upper and lower limits to the min and max values in this time range. This confers the possibility to read the min/max from the axes' captions.

Events / Errors: The number of EVENTS or ERRORS registered on this channel is displayed on the corresponding badge. Click or touch directly on the EVENTS or ERRORS badge to open ERRORS LIST / EVENT LIST overlay.



Figure 14 - SHRcontrol CHANNEL DETAILS with EVENT OVERLAY

Here you can select an EVENT or ERROR by scrolling the list using the rotary (RT1, Figure 4: front panel SHR, 4 channels), or remotely by mousewheel or keyboard cursor keys. Then you can press the context action CLEAR ONE to reset the select event or click CLEAR ALL to reset the complete list.

Channel info bar



Figure 15: Channel info bar

CHANNEL DETAIL elements overview

ELEMENT	DESCRIPTION
CHANNEL NAME	Channel number
CHANNEL STATUS	GREEN: OK YELLOW: Channel is RAMPING RED: ERROR occurred GRAY: channel is OFF Remote usage: CLICK on CHANNEL STATUS to switch channel ON or OFF
CHANNEL INFO	Displays indicators of channel properties: CV: constant voltage mode CC: constant current mode LC: Low Current Mode INH: INHIBIT is ACTIVE TRIP: current trip is active VLIM: Voltage Limit is exceeded ILIM: Current Limit is exceeded EMGCY: emergency mode active
EVENT COUNTER / ERROR COUNTER	Indicates the number of errors (RED) or events (ORANGE) occurred Remote and touch usage: CLICK on badge to open ERROR or EVENT LIST overlay
MEASURED VOLTAGE	Measured voltage of this channel using the configured unit and precision (see MENU / HARDWARE / DISPLAY for configuration)
MEASURED CURRENT	Measured current of this channel using the configured unit and precision (see MENU / HARDWARE / DISPLAY for configuration)
VOLTAGE SET VALUE	Voltage Set value in configured unit
CURRENT SET VALUE	Current Set value in configured unit

Table 14

4.9.5 Voltage / Current settings screens

The VOLTAGE SETTINGS and the CURRENT SETTINGS are accessible directly from the CHANNEL LIST and from the CHANNEL DETAILS by clicking the corresponding context buttons BT_2 and BT_3.

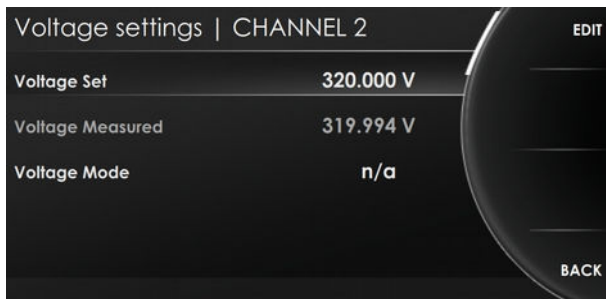

Figure 16 - SHRcontrol CHANNEL-DETAIL VIEW

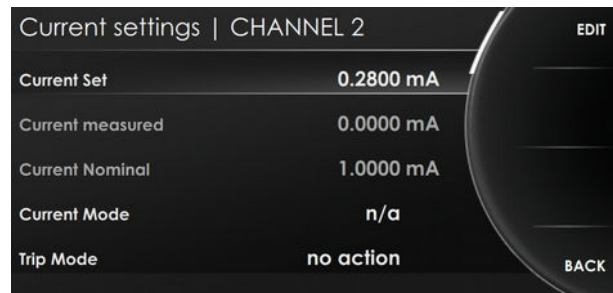

Figure 17 - SHRcontrol CHANNEL-DETAIL VIEW

Select a list entry by rotation of the rotary knob (RT1) or remotely using the mouse wheel or cursor keys on the keyboard. Then use to following context options will be available:

Press "**BACK**" to reenter the parent menu

Press "**EDIT**" to change a value

After choosing EDIT the EDIT MODE will be active (wheel element turns to orange) and you can change entries depending on the value type by using the rotary, the mouse wheel or the cursor keys. The following context options will be available:

Press "**APPLY**" to commit the value change and save it to configuration

Press "**AUTO-APPLY**" to commit the value changes done with rotary automatically, if AUTO-APPLY is ON it is highlighted

Press "**DIGIT**" to move the digit marker. The marked digit will be increased or decreased by rotary (RT1)

Press "**CANCEL**" to cancel the change and return to the previous value

Press "**DEFAULT**" to reset the value to the factory default value

If wrong values were entered or reached Min/Max borders (e.g. Set voltage limits by nominal, mode or hardware limit) the wheel color indicates an error (wheel turns yellow). After applying a value the success will be displayed by turning the wheel to green for a 1second.

Note:

The refresh of the displayed value using the SHRcontrol remotely can take up to 2 seconds.

VOLTAGE SECTION		CURRENT SECTION	
Voltage Set	Set voltage in the configured preferred unit and resolution	Current Set	Set current in the configured preferred unit and resolution
Voltage Measured	Measured voltage in the configured preferred unit and resolution	Current Measured	Measured current in the configured preferred unit and resolution
Voltage Mode	Displays the actually selected voltage of the output mode, which can be configured in Channel Setup	Current Mode	Displays the actually selected current of output mode, which can be configured in Channel Setup
		Trip Mode	Select the possible trip behaviour (see section Current trip)
		Delayed Trip time	Select the desired delay time for the Trip Mode selected action after a current trip occurred

Table 15

4.9.6 Settings menu

The SETTINGS MENU can be started directly from the HOME SCREEN. Depending on the select list entry the context buttons BT_1 to BT_4 show the following actions:

- Press **"SELECT"** to enter a submenu of the selected list entry
- Press **"BACK"** to reenter the parent menu
- Press **"EDIT"** to change a value
- Press **"APPLY"** to commit the value change and save it to configuration
- Press **"CANCEL"** to cancel the change and return to the previous value
- Press **"DEFAULT"** to reset the value to the factory default value
- Press **"OK"** to run an action, for example CLEAR ALL events and errors

INFORMATION



INFORMATION

Readonly entries will be shown in grey text color and can not be edited, so no action will be available.

INFORMATION



INFORMATION

"n/a" is displayed, when the current device does not support this configuration item or value could currently not be received from the device.

Select box values can be changed by using the rotary or remotely clicking the arrows.

Numeric values can be changed by using the rotary for increasing or decreasing value or can be entered directly using the screen keyboard or the device keyboard (remotely).

Alpha numeric values can be entered directly using the screen keyboard or the device keyboard (remotely).

Note:

Values will be cleared by starting typing. To add or change existing text, move cursor first.

The **settings menu** (HOME → Settings) has the following structure:

Level 1	Level 2	Level 3	Level 4	Type / Options	Default	Notes / Description		
HARDWARE SETUP	DEVICE SETUP	MEASUREMENT	ADC-Samplerate	5, 10, 25, 50, 60, 100, 500	500 ² / 50 ³	How many samples are measured per second		
			Digital Filter Averages	1, 16, 64, 256, 512, 1024	64	How many samples are averaged to on		
		CONTROL	Global KILL ENABLE	Enabled / Disabled	Enabled			
			Fine Adjustment	Enabled / Disabled	Enabled			
		HARDWARE LIMITS	Hardware Voltage Limit	0 – 102 % (readonly)	102 %	Device specific hardware limit relative to nominal voltage. Adjustable with hardware limit potentiometer.		
			Hardware Current Limit	0 – 102 % (readonly)	102 %			
		DISPLAY	Display Brightness		10 – 100 %	50 %	Display brightness	
			Display Standby time		0/ 2/ 5/ 10/ 30/ 60/ 120 min	10 min	Display will standby after x minutes	
			Voltage resolution		1, 2, 3, 4, 5	4	Number of digits displayed after separator	
			Current unit		µA, mA	mA	Preferred unit for displaying current values	
			Current resolution		1, 2, 3, 4, 5	4	Number of digits displayed after separator	
			Low Current unit ⁴		µA, mA	µA	Preferred unit for displaying current values for Low Current Range (see hardware specs)	
			Low Current resolution ⁵		1, 2, 3, 4, 5	4	Number of digits displayed after separator for Low Current Range (see chapter 3 Technical data)	
		DATE & TIME	System date		YYYY-MM-DD	2020-05-20	System year	
			System time		HH:mm:ss	13:00:00	System time in 24 hour format	
		CHANNEL SETUP	ALL CHANNELS CH 0-3	Polarity		Positive / Negative		Select polarity of selected channel
				Output Mode		6 kV / 2 mA 4 kV / 3 mA 2 kV / 4 mA		Device dependent channel output mode of selected channel, (see chapter 3 Technical data)
				Voltage Ramp Up			V / s	Voltage increase speed for selected channel(s), limited by output mode, hardware limits
				Voltage Ramp Down			V / s	Voltage decrease speed for selected channel(s), limited by output mode, hardware limits
	Current Ramp Up					mA / s	Current increase speed for selected channel(s), limited by output mode, hardware limits	
	Current Ramp Down					mA / s	Current decrease speed for selected channel(s) limited by output mode, hardware limits	
	INHIBIT Mode							Select the possible INHIBIT behaviour

- 2 SHR Standard
- 3 SHR High Precision
- 4 Only SHR High Precision
- 5 Only SHR High Precision

Level 1	Level 2	Level 3	Level 4	Type / Options	Default	Notes / Description
	INTERFACES	Ethernet	DHCP	Enabled / Disabled	Enabled	Ethernet interface obtains IP by DHCP server
			IP-Address	IP address	192.168.0.1	Fixed IP address (used when DHCP is off)
			IP-Mask	IP mask	255.255.255.0	IP Mask when fixed IP address
			DNS	IP address	192.168.0.254	Nameserver when fixed IP address
			Gateway	IP address	192.168.0.254	Standard Gateway when fixed IP address
			NTP Time server	IP or host name	0.pool.ntp.org	Host address or IP of a NTP timeserver
		Wireless	Enable Wifi	Enabled / Disabled	Disabled	Enable/disable wireless feature (needs iseg certified USB WiFi adapter at USB-AUX port)
			IP-Adress	192.168.1.1 (fixed)		Factory fixed IP address of the WiFi network created by the device
			SSID	Text	iseq-ICS	Enter the desired SSID (wifi network name)
			WiFi Channel	1, 2, 3, 4, 5, 6, 7, 8, 9, 10, 11	1	WiFi channel
			WiFi Password	Text	password	WiFi password
USB	Save USB drivers	Do		Save "linux-cdc-acm.inf" to "iseq-ICS" directory on USB flash memory at AUX port.		
	Unmount USB device	Do		Unmount the USB flash from system		
SOFTWARE SETUP	HTTP interface	HTTP interface		Enabled / Disabled	Enabled	Enable / Disable HTTP interface
	HAL interface	HAL interface		Enabled / Disabled	Enabled	Enable / Disable HAL interface
	EPICS IOC	EPICS IOC		Enabled / Disabled	Enabled	Enable / Disable EPICS IOC server
	SNMP	SNMP		Enabled / Disabled	Disabled	Enable / Disable SNMP server
CLEAR / RESET / BACKUP / RESTORE	Clear events and errors			SET		All caught events and errors will be reset. This allows reenabling of voltage generation when suppressed. Press OK Button to commit action.
	Set values reset			SET		Resets all set values (V=0, I=max) Press OK Button to commit action.
	Factory reset			SET		Sets all values and configuration to factory default (HV unit flash memory values and iCS configuration reset (similar to RESET_IC3 by USB) Press OK Button to commit action.
	Save configuration			Do		Save icsConfig.xml configuration file to USB Flash memory by input e.g. icsConfig-Profile1.xml.
	Restore configuration			Do		Restores of an iCS configuration file from USB Flash memory to icsConfig.xml of SHR. Select one of the saved XML files by using the rotary or the mouse wheel. Press CONTROL RESET button in order to activate the configuration.

Level 1	Level 2	Level 3	Level 4	Type / Options	Default	Notes / Description
DEVICE INFO	Device temperature			Info	Readonly	Current temperature of the device.
	Device model number			Info	Readonly	Full item code number of SHR model
	Device serial number			Info	Readonly	Serial number of SHR device
	Firmware name			Info	Readonly	Firmware name of HV hardware
	Firmware release			Info	Readonly	Firmware release number
	INHIBIT			Info	Readonly	INHIBIT case for external TTL signals
	iCS version			Info	Readonly	ICS system version number
	Connected clients			Info	Readonly	Number of currently connected clients to SHR
	CAN bus state			Info	Readonly	CAN bus diagnostic information
	CAN bus information			Info	Readonly	CAN bus diagnostic information
REMOTE ⁶	Remote host			IP or host name	lcs.iseq-hv.com	IP or host name of the SHR the SHRcontrol should connect to
	Remote port			Port	8080	The websocket port of the SHR device that should remotely connect
	User			Username	demo	Enter the username of a valid user at the SHR ⁷
	Password			Password	demo	Enter the password of a valid user at the SHR ⁸

Table 16: settings menu

6 Available for SHRcontrol in remote mode (e.g. as Desktop application, see chapter 12 Appendix)

7 The default user of an iCS installation is "admin" - it can be changed using the iCSconfig web tool - see iCS configuration chapter 5 iCS2 - iseg Communication Server

8 The default password of an iCS installation is "password" - it can be changed using the iCSconfig web tool - see iCS configuration chapter 5 iCS2 - iseg Communication Server

4.9.7 Graph plugin

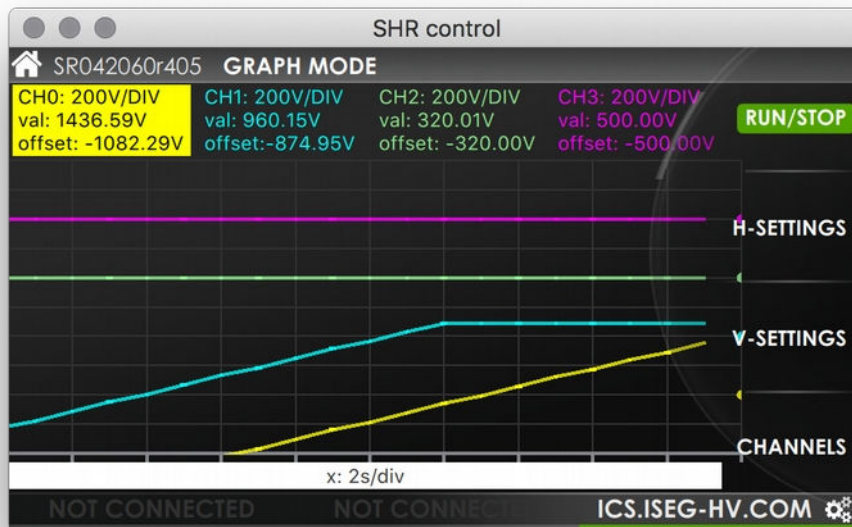

Figure 18 - SHRcontrol GRAPH MODE

The graph plugin visualizes voltage and / or current flows of up to 4 SHR channels in one plot.

On the top of the plugin the SET VALUE, the MEASURED VALUE and the OFFSET POINT of voltage or current are visible. To change the CHANNEL GRAPH SETTINGS you can directly click or touch on the respective area. Then it will be highlighted and the context buttons change to the channel's settings page.

On the bottom a white handle bar indicates the currently set X-axis resolution and can be dragged by touch or mouse to scroll the graph back.

The following context menu structure is available in the GRAPH MODE plugin:

MENU	BT_1	BT_2	BT_3	BT_4
GRAPH HOME	RUN / STOP Toggles run or stop of data acquisition and scope updating	H-SETTINGS Enter H-SETTINGS menu for horizontal setup	V-SETTINGS Enter V-SETTINGS menu for vertical setup	CHANNELS Enter GRAPH CHANNELS – SETTINGS
H-SETTINGS	SCALE Increases or decreases the horizontal resolution of the scope	SHIFT Moves the scope left or right by using the rotary RT1 or the mouse wheel	LATEST DATA Shifts scope to latest data received	BACK Returns to GRAPH HOME menu
V-SETTINGS	AUTO ALL Sets vertical mode to AUTO ALL: Using this mode all channels will be scaled to a common scale factor. The offset will be set individually.	AUTO SINGLE Sets vertical mode to AUTO SINGLE: Using this mode all channels will be scaled to individual scale factors. The offset will be set individually.	MANUAL ALL Enter MANUAL ALL menu	BACK Returns to GRAPH HOME menu
MANUAL ALL	SCALE ALL If selected the rotary or mouse wheel can be used to select a vertical scale factor applied to all channels.	OFFSET ALL If selected the rotary or mouse wheel can be used to select a vertical offset applied to all channels.	V/I If clicked the channel settings of all channels will toggle between Voltage and Current	BACK Returns to GRAPH HOME menu
CHANNELS	CH0	CH1	CH2	CH3
Enters GRAPH CHANNELS-SETTINGS for the selected channel				
GRAPH CHANNEL SETTINGS	SCALE If selected the rotary or mouse wheel can be used to select a vertical scale factor applied to the selected channel.	OFFSET If selected the rotary or mouse wheel can be used to select a vertical offset applied to the selected channel.	V / I / OFF If clicked the channel settings of the selected channel will toggle between Voltage, Current or been hidden.	BACK Returns to GRAPH HOME menu

Table 17: Menu structure

4.9.8 More plugins / customization

Iseq permanently develops and improves SHRcontrol. If you need custom specific apps or plugins.

4.10 Factory Reset

Resetting to factory settings (see Table 15) on the SHR sets the parameters

- HV Channels polarity to "POSITIVE"
- HV channels STANDARD output mode (SHR xx 60: 2kV/4mA, SHR xx 20: 2kV/6mA)
- HV channels voltage set to 0 Volt
- HV channels current set to I_{NOM} (see item 2)
- Configure HV channels current measurement high range to mA and low range to μA

Press the button "Control Reset" (see chapter 4.2 Front panel) when finished.

5 iCS2 – iseg Communication Server

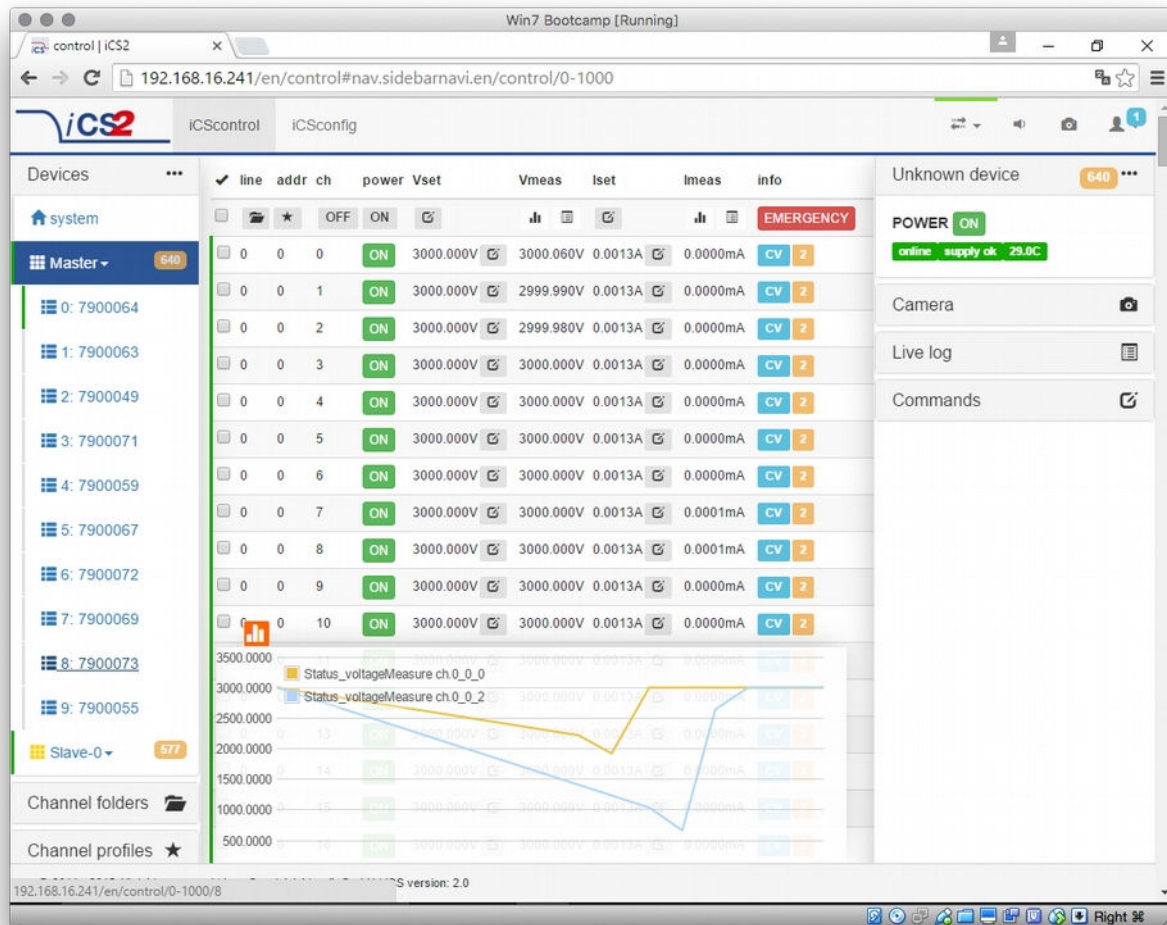

Figure 19: iseg Communication Server

5.1 System description

The iseg Communication Server iCS is a software solution to control iseg high voltage hardware from multiple devices over wired or wireless network. iCS is a manufacturer specific Linux OS, which runs on iseg hardware, like iCSmini2, CC24 crate controller series or SHR Desktop High Voltage Power Supply.

The iCS front end is based on browser technology to keep installation and maintenance effort low, to enable a quick start for configuration independently from the user's software platform, even on mobile devices.

iCS is equipped with an integrated role and user management, and delivers important software services right out of the box, like EPICS IOC, OPC server, SNMP interface, HTTP and webservice to give a quick access to iseg hardware.

iCS also delivers configuration utilities and straight forwarded tools for firmware upgrading process.

The installed iCS2 libraries and services licenses files are located on the system under:

/usr/share/common-licences/[library or service module]

iCS software components	Description	Port / Protocol
iCSconfig	Configuration section for iCS software services, restorable hardware configurations, and firmware updates, documentation access and more...	TCP 80 / HTTP
iCScontrol	Multi-user browser based device control, surveillance cam support	TCP 80 / HTTP
iCSservice	Internal websocket based server, JSON objects, with clients Push (websocket) or pull (HTTP polling) technology	TCP 8080 / Websocket TCP 8081 / HTTP API
iseqHALservice	iseq hardware abstraction layer service, simple hardware access	TCP 1454 / iseqHAL Socket
EPICS IOC	EPICS Input / Output controller, autoconfiguring to hardware setup, customizable by file upload#	EPICS Base R3.15.7 TCP/UDP 5064, 5065
OPC/UA	OPC / UA server	
SNMP	Simple Network Management Protocol	UDP 161

Table 18

5.2 Software architecture



Figure 20: Software architecture

5.2.1 How to connect via WiFi

- 1) Make sure to have the WiFi adapter onboard or external installed, all modules are plugged in and CAN connections (if used) are attached. Start the crate or device.
- 2) Use your mobile device or computer to search for existing WiFi networks and select „iseq-iCS_XXXX“ (XXXX is the iCS serial number).
Enter the factory default WiFi password (password).
- 3) Open a recommended web-browser like Google Chrome and enter the factory default IP address (192.168.1.1)
- 4) Enter the factory default username (admin) and password (password)

INFORMATION



INFORMATION

WiFi support can be turned off in iCSconfig → WiFi. The default WiFi password can be changed there also.

5.2.2 How to connect via Ethernet

For Ethernet connections with the use of factory defaults, it is necessary to know the IP address of the iCS server first.

By default the iCS is configured to obtain the IP automatically by DHCP. To discover the IP address of the iCS, a small software application iCSfinder can be used. It scans the local network for running iCS services. More details are in the INFORMATION box below. iCS also provides UPnP messages, which can be discovered, e.g. in Windows using „Network“ environment. For Linux and MAC, Zeroconf/Bonjour can be used to find the iCS.

INFORMATION



INFORMATION

To discover iCS installations on the local network, a small utility iCSfinder can be used.

It can be downloaded here: <https://iseq-hv.com/download/?dir=SOFTWARE/iCS/iCSfinder/>

Note: If you wish to set a fixed address without preconnecting via DHCP, please use a (temporarily) WiFi connection to setup OR follow the instructions of (re)setting the ethernet settings (see chapter 5.3.1 Ethernet configuration)

Hint: If you experience problems using iCSfinder, please try using free software tools like “IP SCANNER” / MAC or “ADVANCED IP SCANNER” (Windows)

- 1) Make sure to have the network cable, all modules plugged in and all CAN connections if used attached. Start the crate.
- 2) Open a recommended web-browser and enter the current IP address (see preparations before).
- 3) Enter the factory default username (admin) and password (password).

5.2.3 iCSconfig: manage hardware, service and preferences

iCS has a comprehensive set of configurable properties. All of them are stored in an XML file, to keep configuration flexible. This enables the possibility to have multiple configuration setups stored and restored using the import / export utility.

iCS config sections	
iCScontrol Setup	Manage preferences of iCS web control application
Hardware	Manage connected hardware, set configurations, auto configure, start firmware updates
Ethernet	Manage Ethernet port settings of the iCS
Wifi	Manage wireless access point of the iCS
Users	Create / edit / delete iCS users
Roles	Create / edit / delete iCS roles
Access Control Lists	Grant / deny rights on user / group / channel / item base
iCSservice	Configure iCSservice API / HTTP API
HAL/HALservice	Configure HAL logging and HALservice credentials
EPICS	Configure the embedded EPICS Input/Output controller (IOC)
OPC	Configure the embedded OPC/UA server
SNMP	Configure the embedded SNMP server
Updates	Download updates (System, Product database, firmware) from internet
Custom Scripts	Configure the custom Python3 scripts
Import / Export	Save and restore complete iCS configuration to backup hardware setup

Table 19

5.3 Hardware

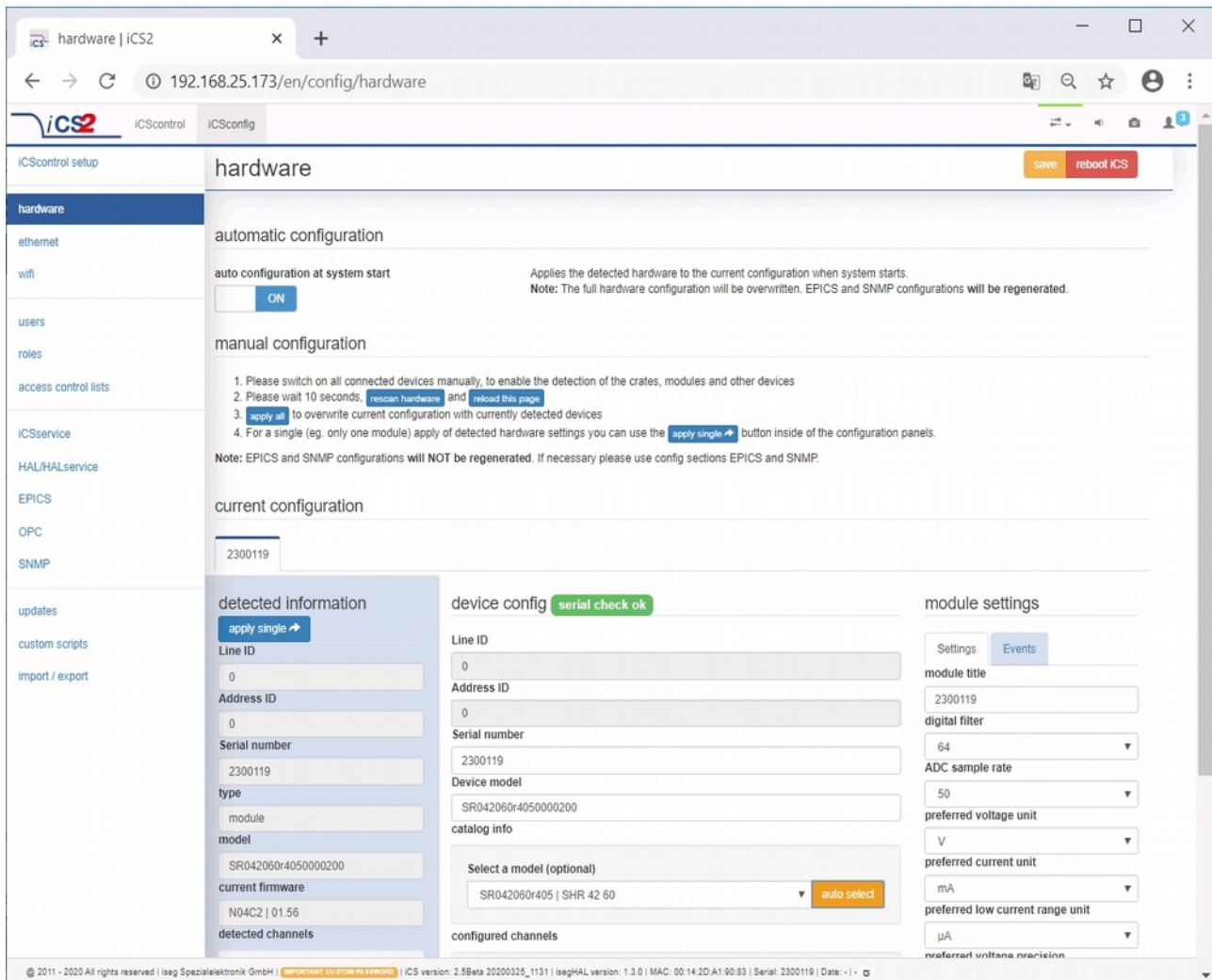

Figure 21: Hardware

In the hardware section, all iCS connected devices like connected crates, controllers and modules are listed and configurable. Each device is represented by a tab, modules and controllers are nested into their responding crates. The CAN lines of the crates are presented with a yellow or green upper tab border (corresponding to yellow or green CAN line), master crates and modules in legacy crates with a blue upper tab border.

The configuration is stored independently from the current hardware setup or connected states. This gives the opportunity to detect misconfigurations and recent hardware setups can easily be restored.

The feature auto configuration at system start supports automatically take over of the detected to the configured hardware, generation of EPICS and SNMP configuration. Auto configuration will be executed one time after iCS system start when master crate backplane is on or when iCS is running on a iCSmini. To apply the complete detected hardware state into the configuration use the apply all button after triggering a rescan using the rescan hardware button. To apply the detected config of just one device (controller or module) use the apply single button under each single tab. The devices information is stored with the information of "module/device config" column. Here the line and address ID are shown and a serial number can be entered (or applied by using auto configuration / apply). If the model of the hardware device could be detected automatically, a model is selected in the dropdown list, otherwise it should be selected manually. Here a FIND buttons checks the list and helps prefiltering the list.

HARDWARE TYPES	
Device	Standalone High Voltage Power Supply
Crate	Case / Bin for a modular HV-supply (module), which supplies power and provides slots for the modules
Controller	Special controller card used in a crate to control, monitors and manages nested modules and crate functions, like switch ON/OFF of crate power supply, monitor temperatures, fans, UPS and more
Module	Modular High Voltage Power Supply, plugged in a slot of a crate, supplied by a CRATE, communication and management by CRATE CONTROLLER, no own POWER ON feature

Table 20: Hardware Types

Information in the row „module settings /device settings“ are module / device specific settings and are stored into the XML configuration file. These settings will get lost when using auto configuration at system start, apply all or apply single functionality.

5.3.1 Ethernet configuration

The ethernet settings of the iCS server hardware (CC2x Crate Controller, iCSmini) can be changed under the ethernet tab. By turning DHCP Client to enabled the iCS will try to obtain an IP address from the local networks DHCP server. Otherwise the IP can be set fixed. Therefore DHCP client must be disabled and IPv4 settings can be entered manually.

ETHERNET FACTORY DEFAULTS	
IP	DHCP
GATEWAY	empty
NAMESERVER	empty
DNS	empty
TIMESERVER	empty

Table 21: Ethernet Defaults

The ethernet settings will be stored automatically to the USB flash memory, directory iseg-iCS as file ip-config.txt whenever an USB flash memory is plugged in. This allows retrieving the current IP configuration from an iCS system.

5.3.2 (Re)set / ethernet configuration

You can reset the ethernet configuration and also set to fixed IP address e.g. cause of problems with DHCP IP relay using the following procedure:

- 1) Shut down all modules/devices and turn off the iCS System by unplugging mains.
- 2) Create an empty file called "RESET_NET.txt" on a USB flash memory drive (FAT32 format)
- 3) Now edit the file. It should contain the following entries, separated by new lines.
- 4) Plug USB flash memory drive into the USB slot at the front panel of the device (CC24, iCSmini2, SHR)
- 5) Plug in mains
- 6) Please wait about 20 seconds until iCS has started completely
- 7) Optional: Plug off the USB flash memory drive and check on a computer if the file created on step 2 was renamed to RESET_NET.txt.done. If it was not renamed, then something went wrong.

CONTENT OF RESET_NET.txt			
LINE	PARAMETER	EXAMPLE	DEFAULT-VALUE
0	IP address / DHCP	192.168.0.10	DHCP
1	NET MASK	255.255.255.0	255.255.255.0
2	GATEWAY	192.168.0.1	192.168.0.1
3	NAMESERVER	192.168.0.1	192.168.0.1

Table 22

INFORMATION	
 INFORMATION	Use quality USB flash memory drives, otherwise the drive might not be detected by the iCS. Also make sure, the flash memory has no file system problems.

5.3.3 WiFi configuration

The WiFi configuration sets the wireless network properties provided by the iCS hardware access point (optional). Generally the WiFi function can be disabled using the WiFi support switch. The IP address of the WiFi is fixed, so once connected with a iCS WiFi the IP address always stays the same.

WIFI FACTORY DEFAULTS	
IP (fixed)	192.168.1.1
SSID	iseq-iCS2_[HARDWARE SERIAL-NUMBER]
Channel	5
Password	password

Table 23

5.4 Users / roles configuration

Users of iCScontrol can be added, edited and removed in the users section. Users can be assigned roles, such like admin, user etc. One or more users can be selected by editing a role.

USER DEFAULTS	
User	admin
Password	password
Role	admin

Table 24

5.4.1 Access Control Lists (ACL)

With the access control list rights to grant or forbid control on special objects for principals (roles or users) is managed. This gives a powerful tool for very detailed rights mechanism.

INFORMATION	
 INFORMATION	<p>Note: Users, roles and ACL are only applied for user authentication for applications and services, which are based on iCSservice. These are iCScontrol, iCSconfig, isegControl, and HTTP API. isegHAL based services should implement their own security mechanisms.</p>

5.4.2 SSH access

The ICS2 Linux host system can be fully accessed as root user using an encrypted SSH shell access over port 22.

This enables the user to install own services or freely configure e.g. EPICS plugins etc.

From factory side, the user account root is enabled, but protected with a secret password. To use the SSH access, you need to setup a custom password. This is described in the next chapter 5.4.3 (Re)set SSH access.

Afterwards, you can use any SSH client, e.g. PuTTY (<https://putty.org>) to log in as root with your custom password.

INFORMATION	
 INFORMATION	<p>The local file system is divided into a system and a user data partition. To make changes on the read-only mounted system part use the following command: <code>mount-rw /</code> and <code>mount-ro /</code> switches the root file system back to read-only.</p>

5.4.3 (Re)set SSH access

INFORMATION	
 INFORMATION	<p>To protect your iCS system, we strongly advice to change the factory SSH password into a custom password. This password allows full system access, so keep this password secret!</p>

For security reasons, changing the SSH password is only possible with direct hardware access using the following procedure:

- 1) Create a file RESET_SSH.txt with your new root Password as content in the first line and save it to an USB flash memory drive (FAT32 format). Note: if the file is empty, the iCS root password will be reset to factory default.
- 2) Plug the USB flash into iCS hardware and reboot iCS.
- 3) The iCS changes the password during the boot process. In case of success the file will be renamed into RESET_SSH.txt.done.

5.4.4 iCS Factory Reset Invocation

In case the user has forgotten his password or simply wants to get back to factory default configuration, it is possible to invoke a factory reset. For factory reset an USB flash drive (USB stick) with a FAT32/FAT16 partition is needed.

CAUTION!



CAUTION!

After factory reset all hardware configurations will get lost!

5.4.5 Instructions:

- 1) Shut down all modules / devices and turn off the iCS System by unplugging mains.
- 2) On the USB flash drive create an empty file called "RESET_ICS.txt"
- 3) Plug the USB flash memory drive into the USB slot at the front panel of the Crate-Controller
- 4) Plug in mains
- 5) Please wait about 20 seconds until iCS has started completely
- 6) In case of success the file will be renamed to RESET_ICS.txt.done.

5.5 iCService configuration

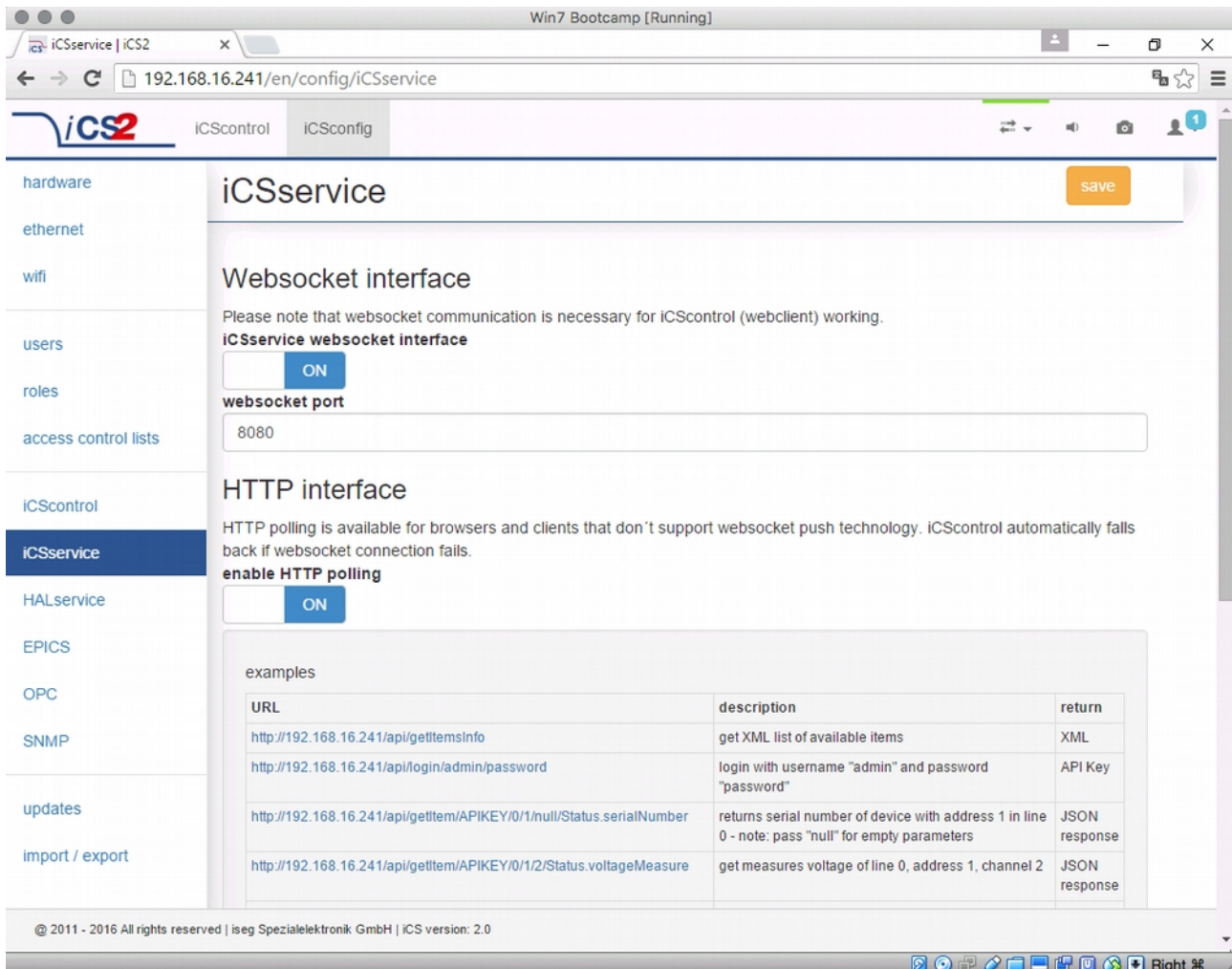



Figure 22: iCService configuration

The iCService running on iCS hardware provides two interfaces, a websocket interface with push technology and a HTTP polling interface, which is fallback for browsers and clients, that do not support websocket technology. Both of them can be disabled, whereas at least one of them is necessary for the correct operation of iCService.

iCService DEFAULTS	
Websocket Port	8080
HTTP port	8081
HTTP URL BASE	<IP-of-iCS>:8081/api/

Table 25

INFORMATION



The documentation of iCService API, step by step connection guide to use Websocket / HTTP interface and an example Javascript is available on iCS directly (iCService / iCService) or online on:
<https://iseq-hv.com/download/?dir=SOFTWARE/iCS/doc/iCService/>

5.5.1 HTTP interface

This interface gives quick access to iCSservice by simple HTTP queries.

iCSservice HTTP functions		
URL, Parameters with leading \$, params not mandatory [\$param]	Response	Description
http://<IP-of-ICS>:8081/api/login/\$username/\$password	API Key	Returns API Key to be identified for session
http://<IP-of-ICS>:8081/api/logout/\$session-ID	TRUE / FALSE	
http://<IP-of-ICS>:8081/api/getItem/\$apikey/\$line/\$address/\$channel/\$item	JSON Object	Returns state of a specific item of a hardware path \$line, \$address, \$channel and \$item can be set by wildcard '*'
http://<IP-of-ICS>:8081/api/setItem/\$apikey/\$line/\$address/\$channel/\$item/\$value/[\$unit]	TRUE / FALSE	Sets state of a specific item of a hardware path \$line, \$address, \$channel can be set by wildcard '*'
http://<IP-of-ICS>:8081/api/getUpdate/\$apikey/	JSON Object	returns all changes collected by iCSservice since last getUpdate call for this client session
Notes: Use "*" as wildcard, e.g. to set or get items on multiple channels at once. Use "null" as empty set identifier, e.g. to obtain module specific objects without channel declaration.		

Table 26

EXAMPLES	
http://192.168.1.1:8081/api/getItem/123456-321/0/1/0/Status.voltageMeasure	Returns voltage value, unit and timestamp of channel 0 of module with address 1 of line 0
http://192.168.1.1:8081/api/setItem/123456-321/0/1/*/Control.voltageSet/1/kV	Set set voltages of all channels of module 1 in line 0 to 1,000 Volt
http://192.168.1.1:8081/api/setItem/123456-321/0/null/null/Control.power/1	Switch controller of line 0 (master) on

Table 27: Examples

5.5.2 EPICS

For the use of iseg hardware with Experimental Physics and Industrial Control System (EPICS), the iCS comes with a preinstalled integrated Input-Output-Controller (IOC). This service can be enabled or disabled using the switch enable EPICS input / output controller. To keep things straight forward, the iCS can generate IOC configuration files (.db and .sub) using the current hardware configuration. Both files can be downloaded to the local computer, edited manually, e.g. with a text editor and uploaded again. This gives a quick start to run an IOC out of the box. To get an overview on all available process variables (PV), which are generated at the start of IOC, the PV list can be downloaded using the respective button. The IOC script combines a process variable definition file (.db) with a substitution file (.sub), which contains hardware setup information and placeholders to create all accessible process variables at run time.

File	Description	Sample content (extraction)
iseg_epics.db	Database file with definitions of PV	<pre>##### # ### Crate item values ### # ##### record(mbbiDirect, "ISEG:\${CONTROLLER_SN}:\${CAN_LINE}:\${ {DEVICE_ID};StatusLow") { field(DESC, "Lower 16 bit of module status register") field(DTYP, "isegHAL") field(INP, "@\${CAN_LINE}.\${{DEVICE_ID}.Status can0") field(NOBT, "16") field(SHFT, "0") field(TSE, "-2") } ... </pre>
iseg_epics.sub	Substitution file contains a pattern that will be substituted by the following lines for each corresponding channel	<pre>{CONTROLLER_SN,CAN_LINE,DEVICE_ID,MODULE_ID,CHANNEL_ID} {5230003,0,1000,0,0,"AUTO"} {5230003,0,1000,0,1,"AUTO"} {5230003,0,1000,0,2,"AUTO"} ... </pre>
iseg_epics.pv	Text file with list of process variables generated	<pre>ISEG:5230003:0:0:0:CurrentMeasure ISEG:5230003:0:0:0:CurrentNominal ISEG:5230003:0:0:0:VoltageMeasure ISEG:5230003:0:0:0:VoltageNominal ... </pre>

Table 28

For more detailed information on EPICS, please visit: <https://epics.anl.gov/>, for sample libraries and test scripts, please contact support@iseg-hv.de.

INFORMATION



INFORMATION

The documentation of iseg EPICS IOC and a sample scripts are available on iCS directly (iCSconfig / EPICS) or online on: <https://iseg-hv.com/download/?dir=SOFTWARE/iCS/doc/isegIOC/>

5.5.3 HALservice

The isegHALservice provides a secure sockets encrypted end-to-endpoint access to the iseg hardware layer running on iCS hardware. The isegHALservice API is similar to isegHAL API, with some specific extension. Please refer Appendix “isegHAL” for details. For an easy start a simple example program isegHalTerminal demonstrates the remote access. There are virtual instruments (VIs) which are based on the library isegHAL-remote in order to control iseg hardware via LabVIEW⁹.

INFORMATION



INFORMATION

The documentation of iseg HAL (service) is available on iCS directly (iCSconfig / HALservice) or online on:
<https://iseq-hv.com/download/SOFTWARE/iCS/doc/iseqHAL/index.html>

5.5.4 SNMP

For backward compatibility of the iCS2 to SNMP controlled systems like WIENER MPOD, iCS2 is able to communicate using the SNMP service.

The service can be enabled or disabled using the switch enable SNMP interface.

Using the current iCS2 hardware configuration a SNMP configuration can be automatically generated. To create a new SNMP configuration, which is compatible to WIENER Configuration file (.mib) please use button “generate configuration” under the SNMP tab in iCSconfig.

For user specific changes of configuration, the .mib (vendor specific definition of data points) and .sub (substitution information with list of hardware channels) files can be downloaded, locally modified and uploaded again.

Please note: local modifications will be overwritten every time the “generate configuration” function will be used.

INFORMATION



INFORMATION

The documentation of iseg SNMPservice and sample scripts are available on iCS directly (iCSconfig / SNMP) or online on: https://iseq-hv.com/download/SOFTWARE/SNMPguide/SNMP_Programmers-Guide_en.pdf

9 © National Instruments Corporation. All rights reserved.

5.5.5 Updates

The following types of updates can be managed with iCS:

Type	Description
base	product database with information about iseg hardware specifications
system	update image of the iCS server operating system (CC, iCSmini)
firmware	firmware update files for iseg devices (like HV modules, crate controllers etc.)

Table 29

All update files can be downloaded from iseg web repository using the CHECK ONLINE FOR UPDATES or using the update UPLOAD function to send a file from the local computer to the iCS server.

Once an update file is available on the iCS, it can be installed using INSTALL or removed by using DELETE Buttons. After using install, follow the instructions shown on the screen.

Firmware files can be unzipped using EXTRACT. After extraction the available firmware files are shown in a list. By clicking INSTALL the iCS tries to apply the selected firmware to all connected devices, that are qualified for (matching item code, online, lower firmware version installed).

To update specific hardware devices please extract the firmware package first and then navigate in the hardware section to the corresponding device and use firmware update functionality individually.

INFORMATION



INFORMATION

Using the Check online for updates feature the iCS directly connects to iseg online software repository. All update files can also be downloaded directly on <http://download.iseg-hv.com/?dir=SOFTWARE/iCS>

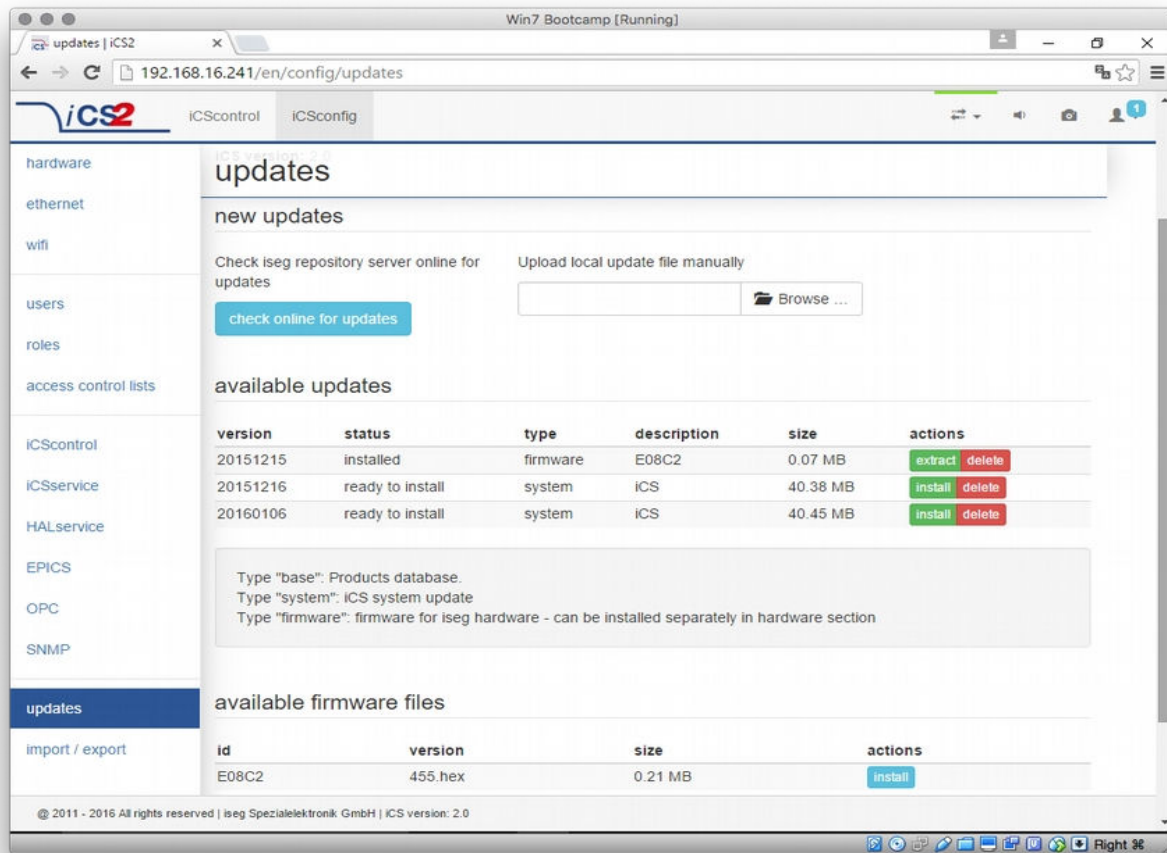

Figure 23: Updates

5.5.6 Custom scripts

The custom script folder provides an access to the script setup. A list of installed scripts will be displayed here.

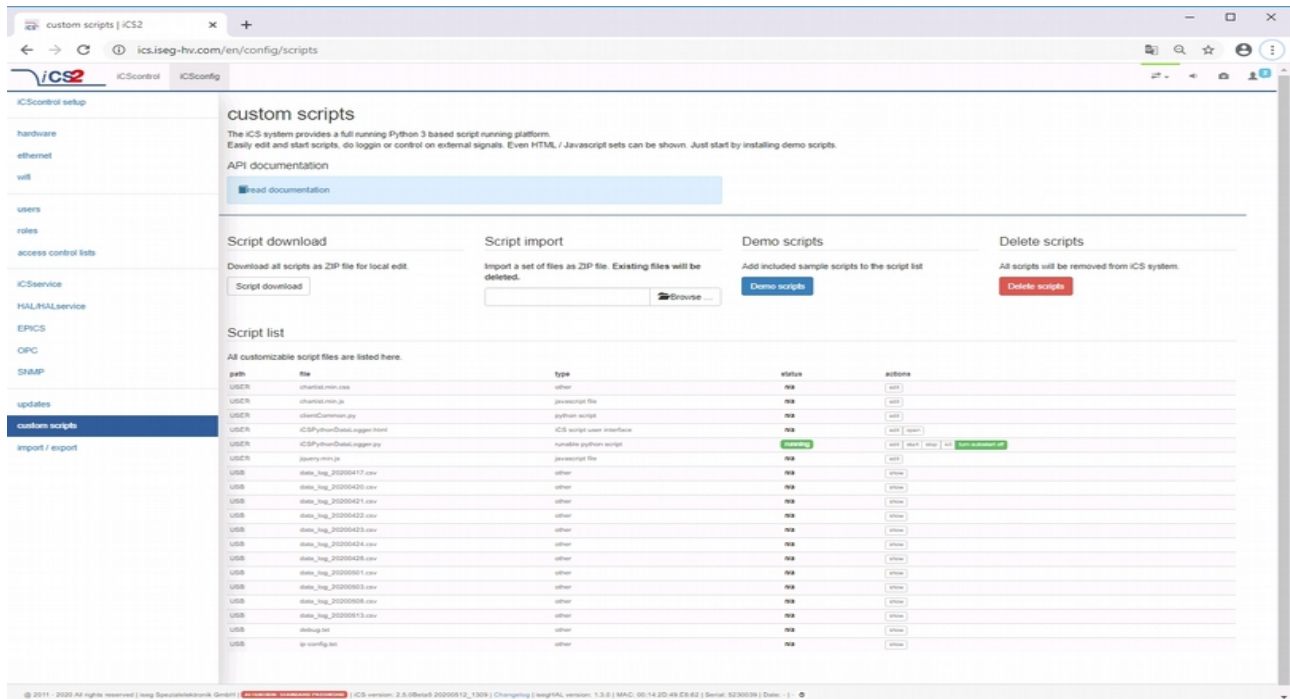

Figure 24: Custom scripts setup

Custom scripts	
Script download	Load a copy of all installed files from iseg hardware <code>/mnt/user/data/scripts</code> as ZIP file to your local download directory
Script import	Import a ZIP file to iseg hardware and extract it to <code>/mnt/user/data/scripts</code> . Existing files will be overwritten.
Demo scripts	Add included sample scripts to <code>/mnt/user/data/scripts</code> on iCS hardware
Delete scripts	All scripts will be removed from iCS system
Edit	An editor window open the selected file to make changes or input additionally contents.
Open	Open iCSPythonDataLogger.html for graphical output of logging data.
Start	Start script execute a python3 process with the scrip
Stop	Send a stop command to the script in order to finish the execution.
Kill	Kill the script execution process
Turn on autostart on	Configure an autostart process for a script when the iCS system will be started.

Table 30: Custom script

5.6 iCScontrol software overview

The user interface of iCScontrol software is divided into three parts. The left bar contains the Devices, Ch folders channel folders and Ch profiles channel profiles. The center bar contains control elements, device and channel process variables with the possibility to output a graphical line plot. The right bar contains a device section, Camera access to an optional USB webcam, Live log for data logging and a field to input single Commands from a list.

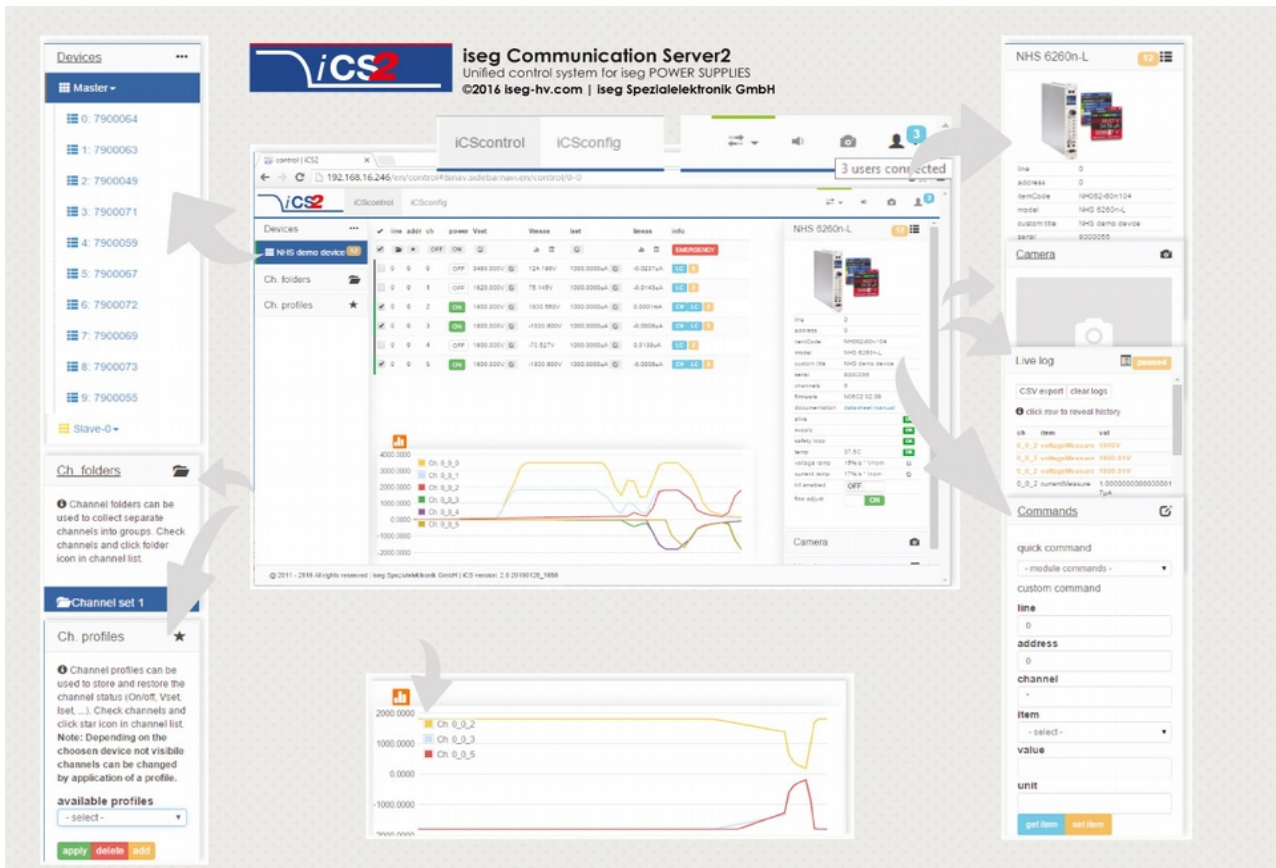

Figure 25: iCScontrol

5.6.1 Left bar: Hardware Explorer

The left column shows the configured hardware.

If connected with iseg CAN line management (starting with CC23) slaves are shown in yellow or green background, corresponding to the CAN line they are connected to. Every device has a colored left border showing the running state.

Crate/Device running states	
gray	all channels of the module are off
yellow	one channel of one of the nested channels is ramping to the desired voltage
red	the crate / device (or one of the nested modules/channels) has one or more errors (refer to the error/event badges)
green	the crate / device (and all of the nested modules) are in a good condition, at least one channel of a nested module is running high voltage

Table 31

Module running states	
gray	not present, not connected or switched off
yellow	one channel of the module is ramping to the desired voltage
red	the module has one or more errors (refer to the error/event badges)
green	the device/module is in a good condition, at least one channel is running high voltage

Table 32

Channel running states	
blurred / faded out	Module is not detected (probably switched off)
gray	not present (configured module to current module mismatch), or switched off
yellow	channel is ramping to the desired set voltage
red	channel has at least one error (please inspect error counter badge)
green	channel is in good condition and switched on

Table 33

5.6.2 Left bar: Channel folders

Channel folders are shown in the section “channel folders” below the hardware section in the left application bar. Channel folders can be created and extended by selecting a set of channels and clicking the folders icon on top of the channel list.

Existing folders can be selected or removed in the folders section of the left bar.

5.6.3 Left bar: Channel profiles

Channel profiles store information about set values, on/off states, and Kill properties of channels. They can be created by selecting the channels that should be restored in the channel list and clicking the star-icon. Existing profiles can be selected, applied and removed in the channel profiles section of the left bar. A new option with the custom given title appears in the select box. By selecting a channel profile and clicking the APPLY button the stored state of the channel will be adjusted.

5.6.4 Center bar: Channel list

Once a device or channel folder has been selected, the channel list will update and show only the corresponding channels, with

- The topological location (line, address, channel),
- The running state,
- Set and measured values,
- Channel info, events and errors (displayed as clickable badges)

The list header has an ACTION ROW, where all channels can be selected with one click for more actions.

Each action in this row is located in top of its respective column.

Some examples:

- To create a new channel folder of specific channels, select these channels and click the folder-icon.
- To store the current setup of the specific channels (running state, set-values, kill enable etc.), select them and click on the star-icon. To enable or disable all selected channels, click the ON / OFF icons.
- Change the set voltages of all selected channels, click the edit-icon which is located in the V_{set} column.
- To display a graph of measured voltages of all selected channels, click on the graph-icon located in the V_{meas} column.
- To show a live log of measured voltages of all selected channels, click on the logtable icon located in the V_{meas} column.

5.6.5 Right bar: Device information

The device section gives information on the currently selected hardware device of the hardware explorer. Depending on the device type, hardware status information are given (temperature, error, safety loop states), the device can be enabled / disabled. Device specific parameters can be set (ramps, kill parameters ...). To get a quick help, hardware documentation can be downloaded directly.

5.6.6 Right bar: Camera

The camera tab shows the captured image of the configured camera. It can be directly connected with the iCS hardware or an IP-Cam URL, configured in hardware / iCScontrol section.

5.6.7 Right bar: Live log

The live log collects information of the current session. The log data is only available until a reload of the iCScontrol web page occurs. The live log can be filtered to specific channels or value types, by selecting channels and clicking the corresponding log icon in the action row on top of the channel list. The log list shows the last value of an item. By clicking on it, previous log items are displayed.

All session log data can be exported as CSV file for ongoing work with spreadsheet applications, eg. Microsoft® Excel.

5.6.8 Right bar: Commands

Commands can be send directly to connected devices. Quick commands are mass operations that can be sent to more devices at one time. The commands tab prefills the input fields according to the selected hardware device (in hardware explorer).

6 Options

6.1 VCT – voltage correction by temperature

This option allows a temperature dependent correction of the output voltage. The temperatures are measured with a distinct sensor for each channel. The temperature sensors are connected via BNC connectors on the backplane of the module. An user-adjustable VCT-coefficient allows to specify a linear relationship between the measured temperature and the output voltage. As an option one sensor per module can be ordered.

6.1.1 Technical data

Sensor type	EPCOS B57867S0502F140
Temperature range	-40 ... 80°C
Accuracy of temperature measurement	±0.5 K (0 ... 60°C)
Resolution of temperature measurement	1 mK (0 ... 60°C)
Temperature update rate	15 updates/min

Table 34: Technical data VCT sensor

6.1.2 Operation

The connector of the temperature sensor must be plugged in the slot of the corresponding channel on the VCT-connector at the rear panel of the HV-module.

A programmable VCT-coefficient for each channel defines the rate and the direction of the voltage correction. The temperatures, measured at the sensors can be read out from the module.

At the time a HV-channel is switched on or the output voltage is set by the user, the module registers the temperature (T_{ref}) of the corresponding sensor and the set voltage as reference values.

If the temperature (T) at the sensor changes, the output voltage is automatically adjusted according to the formula:

$$V = V_{ref} + a \cdot (T - T_{ref})$$

(a – VCT-coefficient)

Example:

A channel is set to 60V. At the time it is switched on a temperature of 25°C is measured. The VCT-coefficient is set to +1V/K. If the temperature now increases to 26°C the output voltage will increase to 61V. (For channels with a negative output voltage the voltage changes from -60V to -61V). A VCT-coefficient of -1V/K would decrease the voltage to 59V.

INFORMATION



INFORMATION

During operation the values for V_{set} are adjusted. If a channel is switched off the adjusted set value will be kept, not the original value set by the user.

If the VCT-coefficient is modified during operation, V_{ref} and T_{ref} are reset to the present values to prevent a sudden voltage change.

If the temperature sensor is dis- and reconnected during operation, V_{ref} and T_{ref} are reset to the present values to prevent a sudden voltage change.

The temperature dependent voltage correction can be deactivated by setting the VCT-coefficient to 0 or by disconnecting the temperature sensor. If this is done during operation, the channel will keep the actual voltage set.

If the temperature sensor is disconnected a temperature of -273.15°C is shown for that channel.

The VCT data points are described in the manual "iseg Hardware Abstraction Layer" (see chapter 12 Appendix).

6.2 IHB – BNC connectors for Single channel INHIBIT

Single channel INHIBIT via BNC connectors (one per channel), located on the backplane of the module.

6.3 IHD - Detector INHIBIT

The option IHD is a special version of a single channel INHIBIT to be connected to the HV INHIBIT outputs of detectors/preamplifiers from Ortec and Canberra. In order to enable the HV generation either a positive voltage signal (Canberra) or a negative signal (ORTEC) must be applied. The INHIBIT signals are connected via BNC connector (one for each channel) located on the backplane of the module.

6.4 L – Lower output current (HP only)

The output current is limited to a lower value, e.g. 100 μ A. With this option only one current measurement range available.

6.5 TC – Lower temperature coefficient (HP only)

Improved temperature coefficient of 10ppm/K.

7 Dimensional drawings

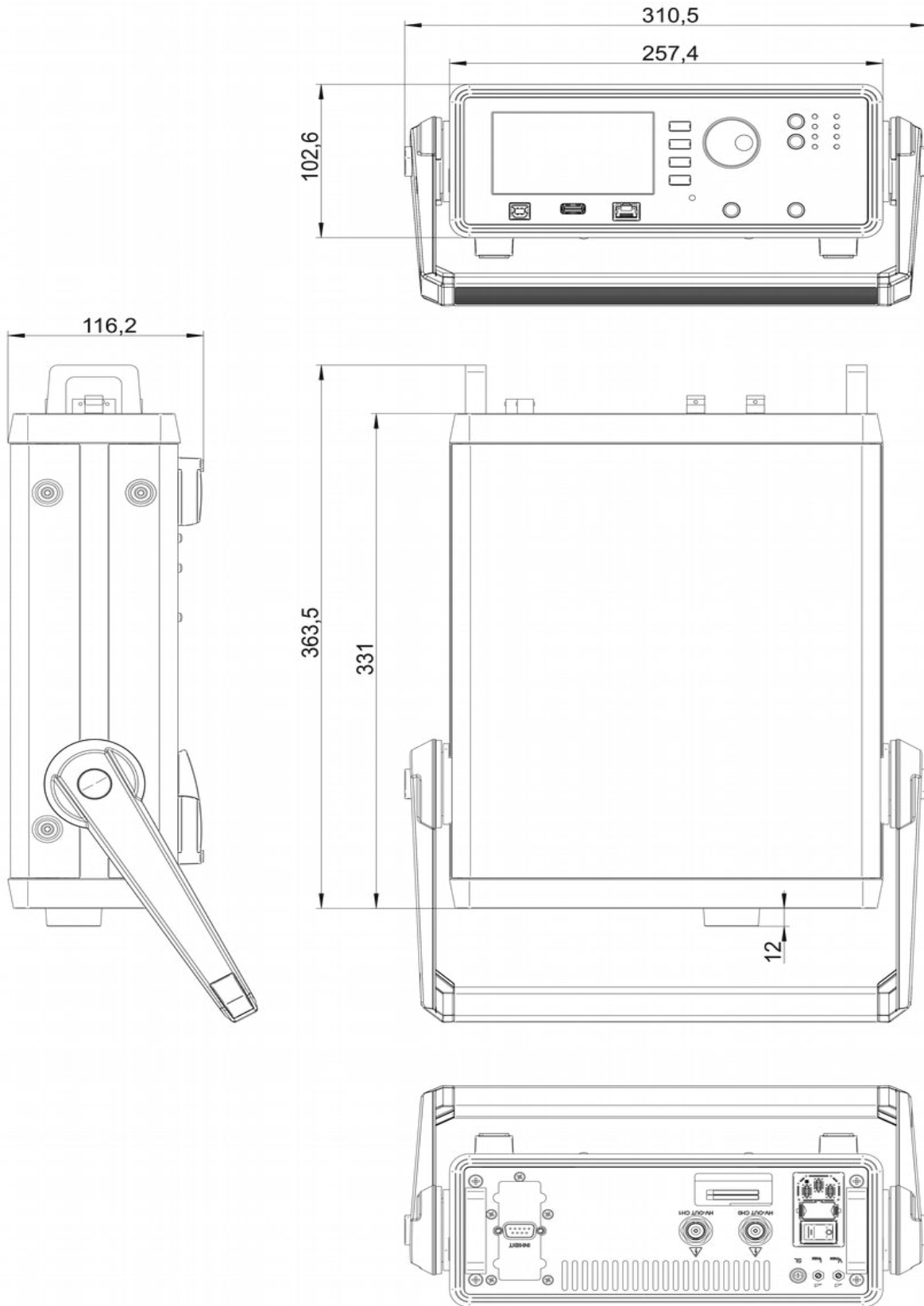

Figure 26: Dimensional drawing – SHR 2-channel version

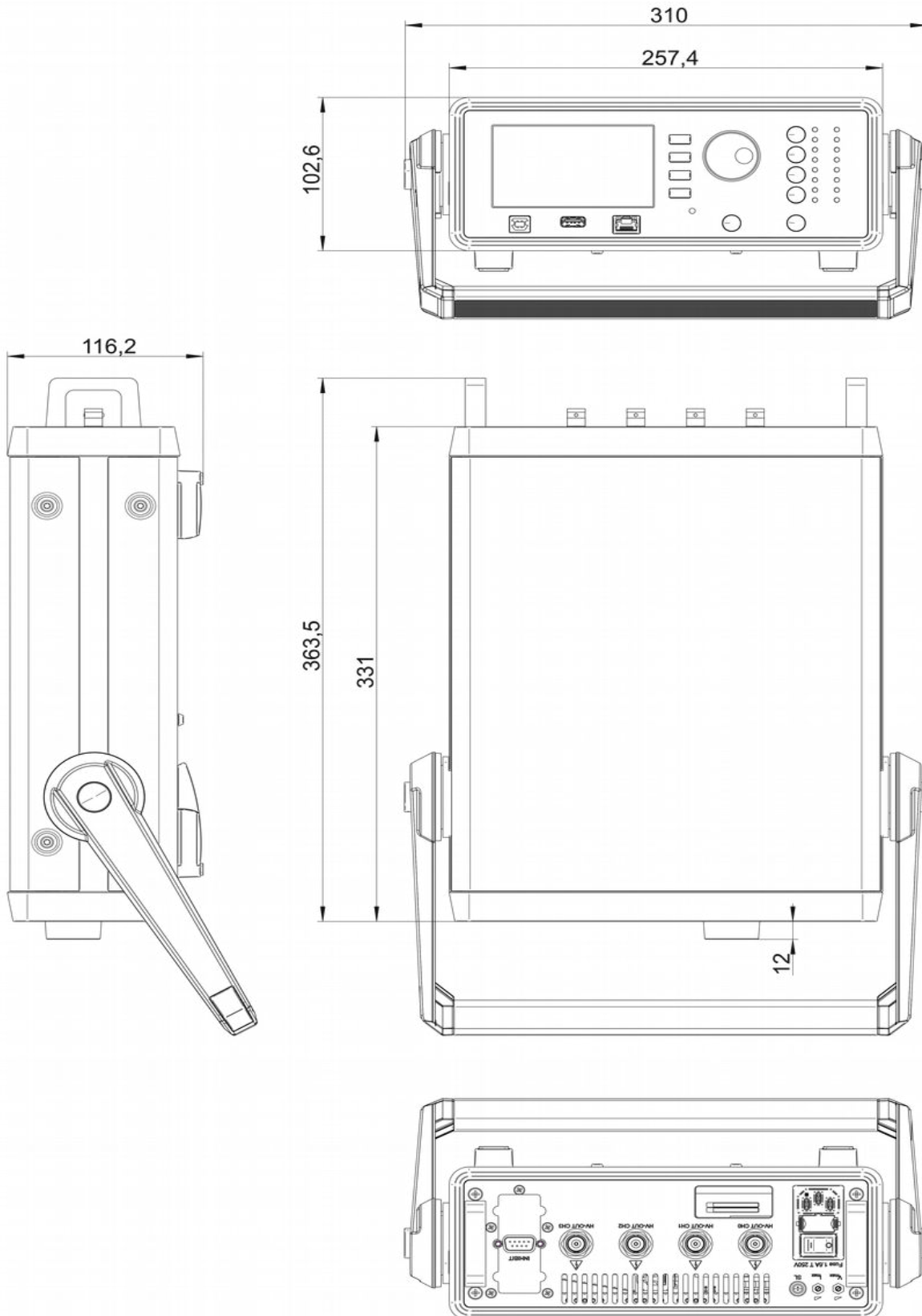

Figure 27: Dimensional drawing - SHR 4-channel version

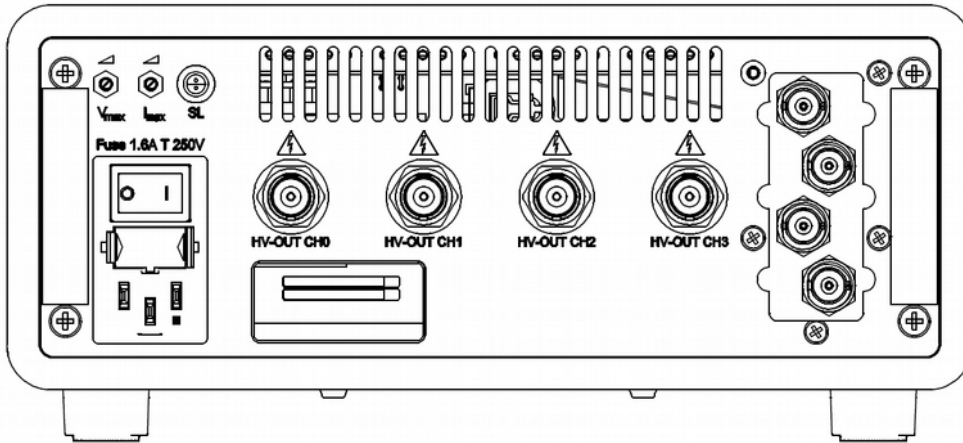

Figure 28: Rear panel with BNC (OPTION IHD, IHB)

8 Connectors assignments





CONNECTORS – POWER SIDE		PART NUMBERS (manufacturer code / iseg accessory parts item code)	
SHV		CABLE SIDE	
 Figure 29	part number	R317.005.000	
	manufacturer	Radiall	
	iseg part number	Z592474	
USB-A AUX		CABLE SIDE	
 Figure 30	connector	USB	USB 1.0/ 2.0, Type A, plug
	manufacturer	various manufacturer	
	iseg part number		
USB-B Remote		CABLE SIDE	
 Figure 31	connector	USB	USB 1.0/ 2.0, Type B, plug
	manufacturer	various manufacturer	
	iseg part number		
INHIBIT D-SUB9 – male		CABLE SIDE	
 Figure 32	connector	D SUB9	
	manufacturer	various manufacturer	
	iseg part number		
RJ45 ETHERNET		CABLE SIDE	
 Figure 33	connector	RJ45	
	manufacturer	various manufacturer	
	iseg part number		
SAFETY LOOP		CABLE SIDE	
 Figure 34	part number	FFA.05.302.CLAC	
	manufacturer	LEMO Elektronik GmbH	
	iseg part number	Z592312	

Table 35: Connectors part number information

9 PIN assignments

9.1 Safety Loop socket

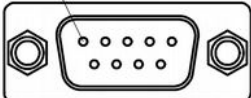
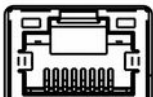
PIN	NAME	DESCRIPTION
1		Safety loop
2		Safety loop

9.2 Inhibit

PIN	DESCRIPTION
1	CHANNEL 0
2	CHANNEL 1
3	CHANNEL 2
4	CHANNEL 3
5	GND
6	GND
7	GND
8	GND
9	GND

Table 36: INHIBIT connector- D-SUB9

10 Accessories

CAUTION!



CAUTION!

Only use genuine iseg parts like power cables, CAN cables and terminators for stable and safe operation.

ACCESSORY ITEM	ORDER ITEM CODE
WiFi USB adapter	Z520175
USB surveillance camera	Z520158
VCT probe	On request

Table 37: Guidelines and item codes for accessories

11 Order guides

CABLE ORDER GUIDE					
POWER SUPPLY SIDE CONNECTOR	V_{max}	CABLE CODE	CABLE DESCRIPTION	LOAD SIDE CONNECTOR	ORDER CODE <i>LLL = length in m</i> ⁽¹⁾
SHV	≤ 5kV	04	HV cable shielded 30kV (HTV-30S-22-2)	open	SHV_C04-LLL
S08	≤ 8kV	04	HV cable shielded 30kV (HTV-30S-22-2)	open	S08_C04-LLL
Notes: ¹⁾ Length building examples: 10cm → 0.1, 2.5m → 2.5, 12m → 012, 999m → 999					

Table 38: Guideline for cable ordering

CONFIGURATION ORDER GUIDE (item code parts)									
SR	04	0	020	r	605	000	02	0	0
High Voltage, Distinct Source	Numbers of channels	Class	V_{nom}	Polarity	I_{nom} (nA)	Option (hex)	HV-Connector	Revision	Customized Version
	02 = 2ch 04 = 4ch	0 = Standard 2 = High Precision	three significant digits · 100V For Example: 020 = 2000V	r = reversible	two significant digits + number of zeros For Example: 605 = 6mA	Sum of the hex codes see Table 6: Technical data: Options and order information For Example: TC = 004	02 = SHV	one digit 0 = no revision For Example: A = first revision	one digit 0 = no customization

Table 39: Item code parts for different configurations

12 Appendix

For more information please use the following download links:

This document
https://iseg-hv.com/download/AC_DC/SHR/iseg_manual_SHR_en.pdf
Archive
https://iseg-hv.com/download/AC_DC/SHR/archive
SHRcontrol desktop application
https://iseg-hv.com/download/?dir=SOFTWARE/isegSHRcontrol/
ICS (iseg Communication Server)
https://iseg-hv.com/download/?dir=SOFTWARE/ICS
SCPI Programmers-Guide
https://iseg-hv.com/download/SOFTWARE/isegSCPI/SCPI_Programmers_Guide_en.pdf
CDC-ACM usb driver for SHR
https://developer.ridgerun.com/wiki/index.php/How_to_use_USB_CDC_ACM_and_MS_composite_Linux_gadget_driver
CAN EDCP Programmers-Guide
https://iseg-hv.com/download/SOFTWARE/isegEDCP/CAN_EDCP_Programmers-Guide.pdf
isegHAL (Hardware Abstraction Layer)
https://iseg-hv.com/download/SOFTWARE/ICS/doc/isegHAL/index.html
isegControl2
https://iseg-hv.com/download/?dir=SOFTWARE/isegControl2/
iseg Terminal
https://iseg-hv.com/download/?dir=SOFTWARE/isegTERMINAL/
ICSservice-API
https://iseg-hv.com/download/SOFTWARE/ICS/doc/ICSservice/ICSapiWebsocket_Docu.html
https://iseg-hv.com/download/SOFTWARE/ICS/doc/ICSservice/ICSapiWebsocket_Example.html
isegIOC (EPICS Input / Output Controller)
https://iseg-hv.com/download/SOFTWARE/ICS/doc/isegIOC/isegIOC_doc.pdf
https://iseg-hv.com/download/SOFTWARE/ICS/doc/isegIOC/isegIOC_sampleScript.zip

Manufacturers website (connectors)	
LEMO Elektronik GmbH	https://www.lemo.com/
Radiall	https://www.radiall.com/

13 Glossary

SHORTCUT	MEANING
V_{nom}	nominal output voltage
V_{out}	output voltage
V_{set}	set value of output voltage
V_{mon}	monitor voltage of output voltage
V_{meas}	digital measured value of output voltage
V_{p-p}	peak to peak ripple voltage
V_{in}	input / supply voltage
V_{type}	type of output voltage (AC, DC)
V_{ref}	internal reference voltage
V_{max}	limit (max.) value of output voltage
$\Delta V_{out} - [\Delta V_{in}]$	deviation of V_{out} depending on variation of supply voltage
$\Delta V_{out} - [\Delta R_{load}]$	deviation of V_{out} depending on variation of output load
V_{bounds}	voltage bounds, a tolerance tube $V_{set} \pm V_{bounds}$ around V_{set}
I_{nom}	nominal output current
I_{out}	output current
I_{set}	set value of output current
I_{mon}	monitor voltage of output current
I_{meas}	digital measured value of current
I_{trip}	current limit to shut down the output voltage
I_{in}	input / supply current
I_{max}	limit (max.) value of output current
I_{limit}	current limit
I_{bounds}	current bounds, a tolerance tube $I_{set} \pm I_{bounds}$ around I_{set}
P_{nom}	nominal output power
P_{in}	input power
$P_{in,nom}$	nominal input power
T	temperature
T_{REF}	reference temperature
ON	HV ON
OFF	HV OFF
CH	channel(s)
HV	high voltage
LV	low voltage
GND	signal ground
INH	Inhibit
POL	Polarity
KILL	KillEnable

14 Warranty & Service

This device is made with high care and quality assurance methods. The standard factory warranty is 36 months. Please contact the iseg sales department if you wish to extend the warranty.

CAUTION!



CAUTION!

Repair and maintenance may only be performed by trained and authorized personnel.

For repair please follow the RMA instructions on our website: www.iseg-hv.com/en/support/rma

15 Disposal

INFORMATION



INFORMATION

All high-voltage equipment and integrated components are largely made of recyclable materials. Do not dispose the device with regular residual waste. Please use the recycling and disposal facilities for electrical and electronic equipment available in your country.

16 Manufacturer contact

iseg Spezialelektronik GmbH

Bautzner Landstr. 23

01454 Radeberg / OT Rossendorf

GERMANY

FON: +49 351 26996-0 | FAX: +49 351 26996-21

www.iseg-hv.com | info@iseg-hv.de | sales@iseg-hv.de