

Electronic DC Loads

HIGH POWER PLI SERIES

Production Series B



- High power density up to 28,800 W
- Basic operating modes CC, CV, CR, CP
- Combined operating modes CC+CV, CR+CV, CP+CV, CV+CC, CR+CC, CP+CC
- Models with several current ranges
- Models with zero voltage, high voltage or extended current range
- Adjustable protections for current and undervoltage
- Optional MPP Tracking
- Optional Test of intelligent chargers
- Master-slave operation
- Dynamic loads with synchronous DAQ
- Data logging directly to USB flash drive
- Functions for testing energy storage devices
- Internal resistance measurement
- Watchdog function in remote operation
- Temporary overload capacity, depending on model
- Electronic protection
- Digital input and programmable control output
- Bilingual help system (German/English)

PLI Series – Brief Profile

The electronic loads of PLI series offer convenient operation via a graphical user interface. The particular strength of the devices lies in the very extensive equipment of interfaces. In addition to Ethernet, USB, RS-232 and analog I/O port, a CAN interface is also installed as standard.

GPIB is optionally available (PLI02).

Setting and measuring smallest currents with high accuracy and resolution is possible with the PLI MR multi-range variant.

Interfaces

- RS-232
- USB
- LAN
- GPIB
- CAN
- Analog
- Analog isolated

Standard Option — not available

Operating Modes

The devices have the basic operating modes constant current, constant voltage, constant resistance and constant power (CC, CV, CR, CP Mode). A limit value for undervoltage and overcurrent can be set in each operating mode.

This allows the combined operating modes CC+CV, CR+CC+CV, CP+CC+CV, CV+CC to be realized.

Protection, Monitoring

- Current protection
- Power protection
- Overtemperature protection
- Overvoltage indication
- Reverse voltage indication
- Undervoltage indication
- Protection of the GND lines at the I/O port

Loading Capacity

The range of models includes power classes from 600 W to 28,800 W.

The models up to 300 V can also be temporarily overloaded. The level and duration of the possible overload power depends on the operating temperature of the power stage. The device displays the currently possible load capacity.

This means that these devices can also be used for significantly more powerful short-term applications.

Cooling

The units are air-cooled. In order to keep the operating noise low, for power classes with 3200 W and more, the fans are steplessly controlled according to temperature and current, smaller models have got 3 cooling steps. For better utilization of the maximum possible overload capacity, the fans can be set to full power.

I/O Port

Analog signals
in realtime!

Standard I/O port for:

- Analog load setting I and V
- Analog setting of I and V protections
- Load on-off
- Analog voltage monitor output
- Analog current monitor output
- Trigger input
- Trigger output
- Digital input and programmable control output

Galvanically Isolated I/O Port (Option PLI06)

Option PLI06 can be installed for galvanic isolation of the analog I/O port from the load circuit.

By using this card ground loops are prevented and it is possible to test bipolar voltages with common analog control using two devices.

Factory Calibration Certificate (FCC-PLIxx)

2 x for free

We supply a free Factory Calibration Certificate (FCC) with the devices. The calibration process is subject to supervision in accordance with DIN EN ISO 9001. This calibration certificate documents the traceability to national standards to illustrate the physical device in accordance with the International System of Units (SI). Within the 2-year warranty period, we will calibrate a second time free of charge if the respective device will have been registered:

<https://www.hoecherl-hackl.com/service/device-registration>

For use under laboratory conditions, H&H recommends a calibration interval of 2 years. This is an empirical value that can be used as a guide for the first period of use. Depending on the intended use, service life, relevance of the application and ambient conditions, the operator should adjust this interval accordingly.

Options, Mechanics and Rack Installation

Option PLI10

Installation kit for 1 device with ½ 19", 2 U



Option PLI11

Installation kit for 2 devices with ½ 19", 2 U



Option PLI12

Installation kit for 1 device with 19", 2 U



Option PLI13

Installation kit for 1 device with 19", 3 U

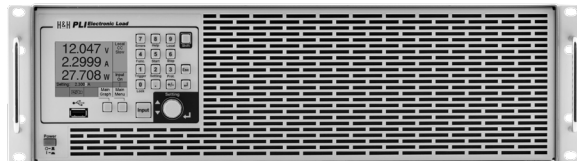

Mechanics



Retractable handle

The PLI series is designed in stable 19" technology and can be used as a desktop unit or installed in 19" racks. From 5 U there are retractable heavy-duty carrying handles on the top of the unit. Optional mounting kits are available for 19" installation for units up to 3,200 W. Larger units are already equipped for installation.

Heavy-Weight Castors (Option PLI14)

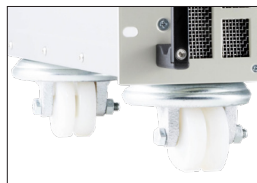

Castors

Steerable castors (option PLI14) can be mounted on large devices for easier transport. This often avoids the need for a 19" rack. This option is available for units from 5 U and upwards and is only suitable for hard floors.

Safety Covers

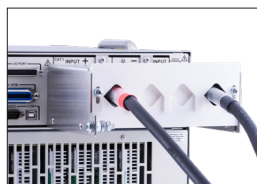

Safety cover for PLI starting from 5 U

For devices for dangerous input voltages, covers are supplied as protection against accidental contact of the load inputs.

Option PLI18

12 V supply input
only for PLI14xx



Input voltage: 11 ... 15 V DC

Option PLI19

12 V supply input
only for PLI32xx



Input voltage: 11 ... 15 V DC

The installation of option PLI19 increases the housing height to 5 U.

Models with Zero Volt Supply (ZV), for High Voltage (HV) or with Extended Current Range (EC)

PLIxxxxZV
PLIxxxxHV
PLIxxxxEC

For applications needing to load the DUT down to almost 0 V (e.g. fuel cell testing) there is the PLI model set PLIxxxxZV. The ZV models can compensate voltage drops on the load lines up to approx. 0.5 V. If the I/O port of a PLIxxxxZV model is to be used, the GND signal of the I/O port must be galvanically isolated from the negative load input. Therefore we recommend to use a galvanically isolated I/O port (option PLI06).

Models for extra high input voltage (HV) or with extended current range (EC) are also available. See model overview starting at page 44.

Models with Multiple Current Ranges (MR)

PLIxxxxMR3
PLIxxxxMR4

Setting and measuring smallest currents with high accuracy and resolution is possible with the models from our MR multi-range variant. There are models with 3 or 4 "real" current and thus resistance and power ranges. The current ranges are graduated with factor 10. See model overview at page 50.

Functions

Overcurrent and Undervoltage Protection

Adjustable overcurrent and undervoltage protections are permanently active. Both protections work in all operating modes.

Undervoltage protection operates in two different modes:

- regulating transition (e.g. CC-CV operation at battery discharge)
- switching transition (short dead time, e.g. when switching the input voltage)

Static Data Logging

At slow processes the electronic load can directly save voltage and current to a USB flash drive. Logging intervals are in the seconds range.

Load Profiles (List Function)

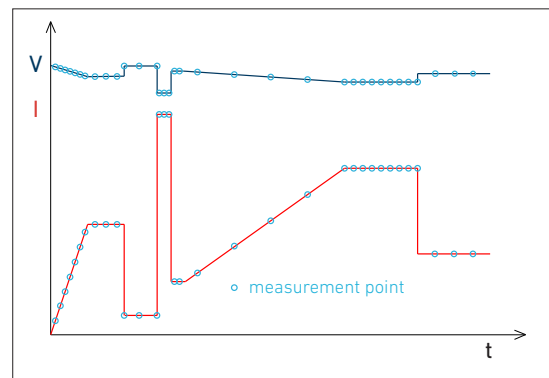

Waveform generated by LIST function with synchronized data acquisition of time, voltage, current

In all operating modes the electronic load can produce load profiles by LIST function. Up to 300 settings with variable dwell and ramp times are possible. Sample times can be defined for each section separately.

The electronic load synchronously measures voltage and current and saves the data with timestamp.

Rectangular Function

New Rectangular		Local
Amplitude (A):	0.000 A	CC
Offset (O):	0.000 A	Med
t high:	0.0002 s	
t low:	0.0002 s	
f = 2.500kHz		Input
D = 50.00%		Off
<input type="button" value="OK"/>		<input type="button" value="ESC"/>

In addition to the list function, the user interface offers a convenient way of generating a rectangular load curve. When operating the load remotely via a data interface, a list of 2 setpoints is simply defined.

Data Acquisition (DAQ)

The electronic load can synchronously store data records of voltage and current with time stamp in a defined interval. Up to 40,000 data records are stored in a ring buffer. After the recording is finished, the data can be read by SCPI queries or transferred to a USB flash drive.

Watchdog Function

To protect the DUT from communication problems, the electronic load in digital remote control mode has a watchdog function that switches off the load input if the previously programmed watchdog delay time expires without the watchdog being reset. The watchdog delay time is set by SCPI command, another command activates the watchdog. When the watchdog is active, a control program must ensure that the command to reset the watchdog is periodically sent to the electronic load.

Trigger Model

Several functions or settings can be triggered by a configurable trigger model:

- Start/stop LIST function
- Start/stop data acquisition
- Set triggered settings of all operating modes

Trigger sources: External, Bus, Manual, Voltage, Current

Discharge Function, Energy Storage Test

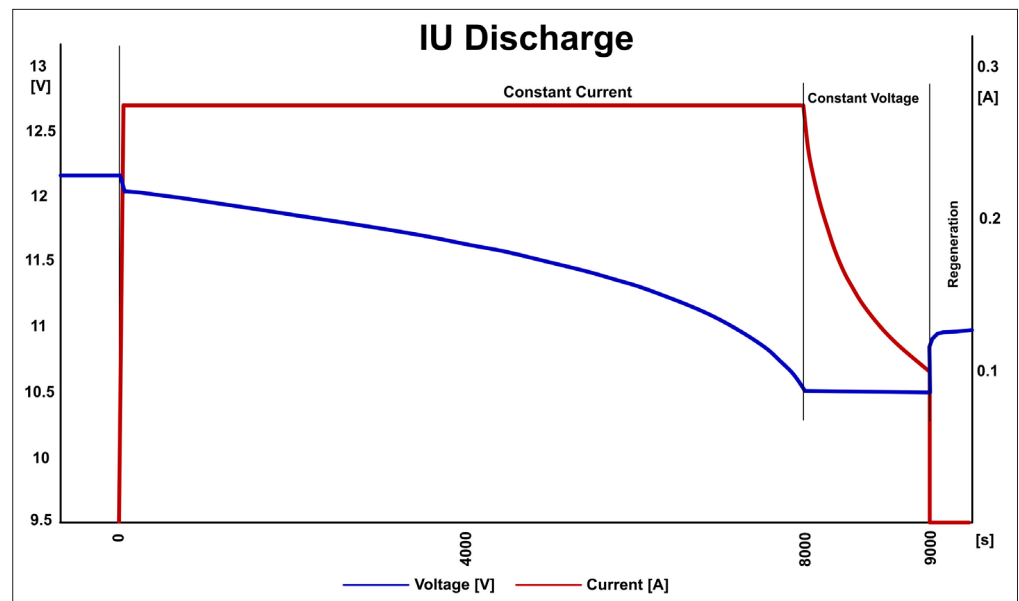

IUa discharge with follow-up time

The discharge function tests energy storage devices such as batteries, ultracaps, electrolytic capacitors and solar panels etc. by discharging them in CC, CP or CR mode. The discharge function can be combined with the list function so that pulsed discharge is possible.

IUa discharge (CC+CV discharge) is also possible: the test object is discharged with constant current up to a defined voltage. This voltage is then kept constant until a defined minimum current is reached.

Stop criteria are charge, energy, time, current, voltage.

During data logging, a follow-up time can be defined to observe the regeneration phase.

Changing Regulation Speed

Sometimes special DUTs or very long load cables require modification of the electronic load's regulation time constant to avoid oscillations and establish stable operation.

Regulation speed slow - medium - fast are selectable at PLI loads.

Internal Resistance Measurement

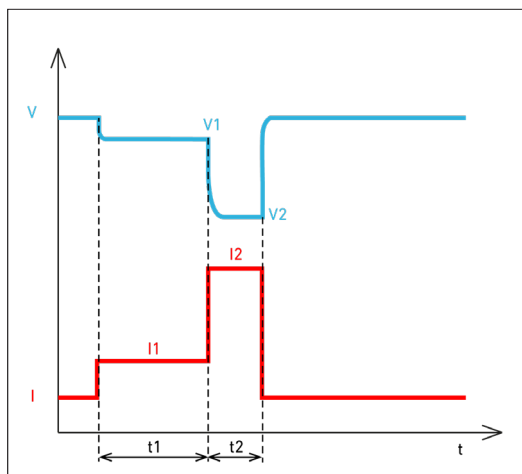

Ri calculation timing

The electronic load can measure the internal DC resistance of the connected DUT. The determination of the internal resistance R_i is based on the principle specified in various standards for batteries and accumulators, e.g. DIN EN 61951, DIN EN 61960. At intervals of a few seconds, the load measures the terminal voltage of the DUT (V_1 , V_2) at two defined load levels (I_1 , I_2) and calculates R_i from this. The load levels I_1 and I_2 as well as their durations are adjustable. In manual mode, the load can store the parameters and the result of the measurement on a connected USB stick at the touch of a button, so that a high throughput with many DUTs can be achieved.

MPP Tracking (Option PLI21)

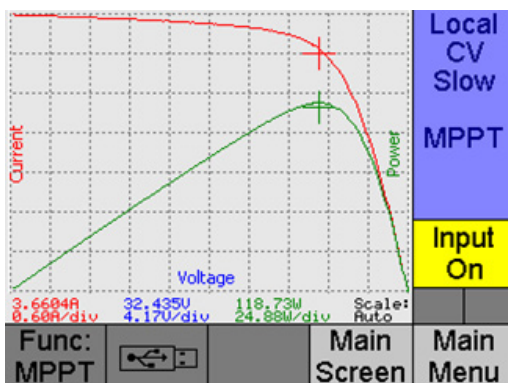

V/I and V/P characteristic at the user interface

The Maximum Power Point Tracking (MPPT) function consists of the two sub-functions Sweeping and Tracking, which alternate continuously in an adjustable interval.

If the measured open circuit voltage at startup is higher than the minimum voltage, the electronic load performs a sweep and then adjusts the global MPP found. The swept V/I curve is displayed together with the V/P curve in the function graph of the user interface. The previously found MPP is marked by a '+' in the diagram. The V/I characteristic can be read out via a data

interface. It is composed as follows:

<Volt_0>,<Curr_0>,<Volt_1>,<Curr_1>,...,<Volt_249>,<Curr_249>

Testing Chargers with the Charger Starter Interface (Option PLI16)

The optional Charger Starter Interface (CSI) is used to test intelligent chargers that do not start charging until they detect a corresponding energy storage device at their output. The PLI load simulates this by applying a certain voltage to the load input for a definable time.

The CSI can be installed in any PLI model with 60 V or 120 V voltage range. In principle, it works like a programmable power supply. The activation of the output voltage can be coupled with the switching of the load input. As soon as the charger supplies current, a predefined voltage list corresponding to the charge curve of the accumulator can be started in the load via trigger.

The load stores the voltage and current measured values with a time stamp. The data can be read out via a data interface or transferred to a USB flash drive.

Master-Slave Operation

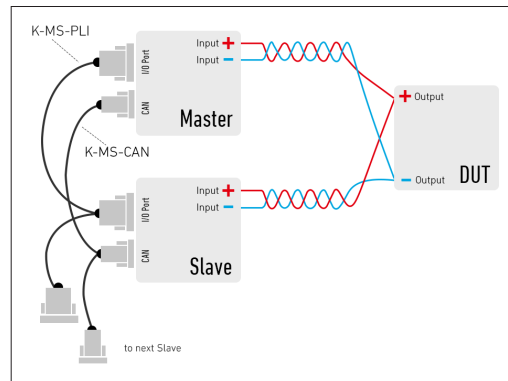

Master-Slave operation in system connection

Up to 5 PLI loads of the same type and firmware revision can be connected in parallel in Master-Slave operation to increase power or current.

The system operates externally as if it were one device. The Master unit regulates the total current of the system, displays the total measured values and delivers these when queried via one of the data interfaces.

Wiring:

A set of Master-Slave cable K-MS-PLI and K-MS-CAN cable in all Slave units (available from H&H or can be assembled by the user).

Limitations:

DAQ functions are not available in Master-Slave operation, functions for setting and reading device parameters are limited. The CAN interface is not available for data communication. When using the Master-Slave cables K-MS-PLI, the I/O port is also not accessible anymore. Nevertheless we offer a "SubD25 Doubler" as an accessory to be able to measure e.g. monitor signals.

Save Settings

In order to be able to quickly reconstruct frequently recurring test tasks, the settings active in the electronic load can be stored non-volatile so that they can be reloaded at a later time. 9 memory positions are available.

The PLI load can optionally set the reset state when switching on, the last active settings at power-off or memory positions 1 to 9.

Drivers



Current NI-certified LabVIEW drivers can be downloaded here:
www.ni.com/downloads/instrument-drivers/

Setting Menu

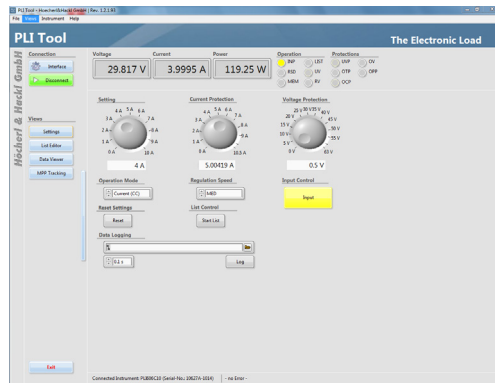

The PLI software tool is a graphical software tool to control the PLI series electronic loads. The user can choose different functions with the aid of the navigation bar. The most important load settings are done in the main menu ("Settings"). Several graphical widgets inform the user about the measurements and the current device status. Further on, a data logging function can be activated in the main menu.

www.hoecherl-hackl.com
 -> Download area

PLI
high power

List Editor

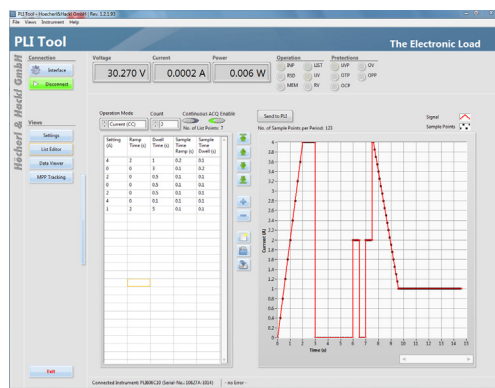

The list editor can be used to easily create dynamic load profiles for the electronic load. The user can enter the nominal setting values for current, voltage, power and resistance, the corresponding rise and fall times and the corresponding dwell times for each setting point of the list. Additionally, the List function allows the user to enable a synchronous data logging function for current and voltage measurements where the sampling times can be individually adjusted for each part of the load profile.

Data Viewer



Measurement values of the internal DAQ memory can be exported from the electronic load and displayed as a diagram with the aid of the "Data Viewer". The measurement data can also be saved on a data storage as a .CSV file for further processing.

MPP Tracking
(with Option PLI21)

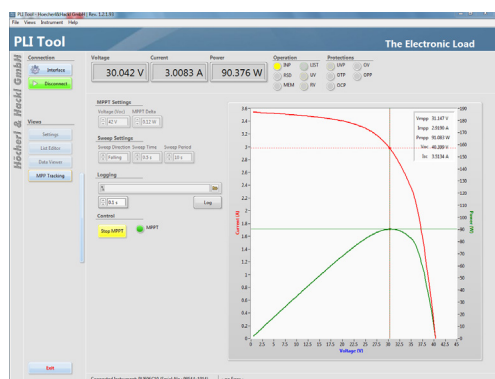

The MPPT function acquires measurement data from a connected solar panel. The function changes continuously between the MPPT process and a sweep process. During the MPPT process, the load controls the optimum global MPP found at the sweep process.

Model (Order number)	PLI606C10	PLI1406C20	PLI2106C30
Maximum input voltage V _{max}	60 V	60 V	60 V
Minimum input voltage V _{min} ¹⁾	1 V	1 V	1.2 V
Maximum current I _{max} ²⁾	10 A	20 A	30 A
Continuous power	600 W	1,200 W	1,800 W
Short-time power ³⁾	600 W	1,200 W	1,800 W
Voltage setting	0 ... 60 V	0 ... 60 V	0 ... 60 V
Current setting	0 ... 10 A	0 ... 20 A	0 ... 30 A
Resistance setting	200 mΩ ... 64.5 Ω	100 mΩ ... 32.2 Ω	67 mΩ ... 21.5 Ω
Power setting ⁴⁾	0 ... 600 W	0 ... 1,200 W	0 ... 1,800 W
Rise/fall time ⁵⁾	30 μs	30 μs	30 μs
Input capacity ca.	2 μF	6 μF	6 μF
Load terminals ⁶⁾ rear / front	BPK4-30L / BPK4-30L	BPK4-30L / -	BPK4-30L / -
Mains voltage ⁷⁾	1/N/PE AC 230 V 50 ... 60 Hz	1/N/PE AC 230 V 50 ... 60 Hz	1/N/PE AC 230 V 50 ... 60 Hz
Mains voltage toggleable ⁷⁾	1/N/PE AC 115 V 50 ... 60 Hz	1/N/PE AC 115 V 50 ... 60 Hz	1/N/PE AC 115 V 50 ... 60 Hz
Power consumption	35 VA	55 VA	75 VA
Noise max. ⁸⁾	55 dB(A)	57 dB(A)	60 dB(A)
Weight ca.	9 kg	14 kg	17.5 kg
Housing / 3D model ⁹⁾	½19", 2 U / PLI_M1	19", 2 U / PLI_M6	19", 2 U / PLI_M6

Model (Order number)	PLI606	PLI612	PLI630	PLI660	PLI680
Maximum input voltage V _{max}	60 V	120 V	300 V	600 V	800 V
Minimum input voltage V _{min} ¹⁾	1.2 V	1.2 V	1.2 V	1.6 V	2 V
Maximum current I _{max} ²⁾	60 A	20 A	16 A	8 A	6 A
Continuous power	600 W	600 W	600 W	600 W	600 W
Short-time power ³⁾	1,200 W	1,200 W	900 W	600 W	600 W
Voltage setting	0 ... 60 V	0 ... 120 V	0 ... 300 V	0 ... 600 V	0 ... 800 V
Current setting	0 ... 60 A	0 ... 20 A	0 ... 16 A	0 ... 8 A	0 ... 6 A
Resistance setting	33 mΩ ... 10.7 Ω	100 mΩ ... 64.5 Ω	125 mΩ ... 201 Ω	250 mΩ ... 806 Ω	334 mΩ ... 1,433 Ω
Power setting ⁴⁾	0 ... 1,200 W	0 ... 1,200 W	0 ... 900 W	0 ... 600 W	0 ... 600 W
Rise/fall time ⁵⁾	35 μs	50 μs	20 μs	20 μs	20 μs
Input capacity ca.	2 μF	2 μF	2 μF	2 μF	2 μF
Load terminals ⁶⁾ rear / front	FKS20/5-SM8 / BPK4-60L	BPK4-30L / BPK4-30L	BPK4-30L / BPK4-30L	BPK4-30L / BPK4-30L	BPK4-30L / BPK4-30L
Mains voltage ⁷⁾	1/N/PE AC 230 V 50 ... 60 Hz	1/N/PE AC 230 V 50 ... 60 Hz	1/N/PE AC 230 V 50 ... 60 Hz	1/N/PE AC 230 V 50 ... 60 Hz	1/N/PE AC 230 V 50 ... 60 Hz
Mains voltage toggleable ⁷⁾	1/N/PE AC 115 V 50 ... 60 Hz	1/N/PE AC 115 V 50 ... 60 Hz	1/N/PE AC 115 V 50 ... 60 Hz	1/N/PE AC 115 V 50 ... 60 Hz	1/N/PE AC 115 V 50 ... 60 Hz
Power consumption	35 VA	35 VA	35 VA	35 VA	35 VA
Noise max. ⁸⁾	55 dB(A)	55 dB(A)	55 dB(A)	55 dB(A)	55 dB(A)
Weight ca.	9 kg	9 kg	9 kg	9 kg	9 kg
Housing / 3D model ⁹⁾	½19", 2 U / PLI_M1	½19", 2 U / PLI_M2	½19", 2 U / PLI_M2	½19", 2 U / PLI_M2	½19", 2 U / PLI_M2

1. Minimum voltage for maximum load current, linear derating to 0 V.
2. Each current range of a higher voltage class in the same power class can be chosen as special current range.
3. Level and duration of short-time power see diagram in technical data at page 53.
4. The setting range reaches up to the short-time power.
5. Rise and fall times are defined from 10 ... 90 % and 90 ... 10 % of maximum current at "fast" regulation speed (constant current mode, Tolerance ±20 %). Rise and fall time in „medium“ regulation speed: ca. 150 μs, „slow“: ca. 2 ms.
6. Description of available terminals starting at page 109.
7. Mains voltage tolerance: ±10 %
8. Measured at the front in distance of 1 m.
9. 1 U = 44.45 mm. Detailed dimensions by means of 3D models at www.hoerchl-hackl.com/downloads.

Model (Order number)	PLI1406	PLI1412	PLI1430	PLI1460	PLI1480
Maximum input voltage V _{max}	60 V	120 V	300 V	600 V	800 V
Minimum input voltage V _{min} ¹⁾	1.3	1 V	1.5 V	1.8 V	2 V
Maximum current I _{max} ²⁾	120 A	40 A	32 A	16 A	12 A
Continuous power	1,400 W	1,400 W	1,400 W	1,400 W	1,400 W
Short-time power ³⁾	2,800 W	2,800 W	2,100 W	1,400 W	1,400 W
Voltage setting	0 ... 60 V	0 ... 120 V	0 ... 300 V	0 ... 600 V	0 ... 800 V
Current setting	0 ... 120 A	0 ... 40 A	0 ... 32 A	0 ... 16 A	0 ... 12 A
Resistance setting	17 mΩ ... 5,37 Ω	50 mΩ ... 32.2 Ω	63 mΩ ... 100 Ω	125 mΩ ... 403 Ω	167 mΩ ... 716 Ω
Power setting ⁴⁾	0 ... 2,800 W	0 ... 2,800 W	0 ... 2,100 W	0 ... 1,400 W	0 ... 1,400 W
Rise/fall time ⁵⁾	35 μs	50 μs	20 μs	20 μs	25 μs
Input capacity ca.	6 μF	6 μF	6 μF	6 μF	6 μF
Load terminals ⁶⁾ rear / front	FKS20/5-SM8 / -	BPK4-60L / -	BPK4-60L / -	BPK4-30L / -	BPK4-30L / -
Mains voltage ⁷⁾	1/N/PE AC 230 V 50 ... 60 Hz	1/N/PE AC 230 V 50 ... 60 Hz	1/N/PE AC 230 V 50 ... 60 Hz	1/N/PE AC 230 V 50 ... 60 Hz	1/N/PE AC 230 V 50 ... 60 Hz
Mains voltage toggleable ⁷⁾	1/N/PE AC 115 V 50 ... 60 Hz	1/N/PE AC 115 V 50 ... 60 Hz	1/N/PE AC 115 V 50 ... 60 Hz	1/N/PE AC 115 V 50 ... 60 Hz	1/N/PE AC 115 V 50 ... 60 Hz
Power consumption	55 VA	55 VA	55 VA	55 VA	55 VA
Noise max. ⁸⁾	57 dB(A)	57 dB(A)	57 dB(A)	57 dB(A)	57 dB(A)
Weight ca.	15 kg	15 kg	14.5 kg	15 kg	15 kg
Housing / 3D model ⁹⁾	19", 2 U / PLI_M6	19", 2 U / PLI_M8	19", 2 U / PLI_M8	19", 2 U / PLI_M7	19", 2 U / PLI_M7

Model (Order number)	PLI2106	PLI2112	PLI2130	PLI2160	PLI2180
Maximum input voltage V _{max}	60 V	120 V	300 V	600 V	800 V
Minimum input voltage V _{min} ¹⁾	1.2 V	1.6 V	1.5 V	1.5 V	2 V
Maximum current I _{max} ²⁾	180 A	60 A	48 A	24 A	18 A
Continuous power	2,100 W	2,100 W	2,100 W	2,100 W	2,100 W
Short-time power ³⁾	4,200 W	4,200 W	3,150 W	2,100 W	2,100 W
Voltage setting	0 ... 60 V	0 ... 120 V	0 ... 300 V	0 ... 600 V	0 ... 800 V
Current setting	0 ... 180 A	0 ... 60 A	0 ... 48 A	0 ... 24 A	0 ... 18 A
Resistance setting	12 mΩ ... 3.58 Ω	33 mΩ ... 21.5 Ω	42 mΩ ... 67.2 Ω	84 mΩ ... 268 Ω	112 mΩ ... 477 kΩ
Power setting ⁴⁾	0 ... 4,200 W	0 ... 4,200 W	0 ... 3,150 W	0 ... 2,100 W	0 ... 2,100 W
Rise/fall time ⁵⁾	35 μs	40 μs	20 μs	20 μs	40 μs
Input capacity ca.	8 μF	8 μF	8 μF	8 μF	8 μF
Load terminals ⁶⁾ rear / front	FKS20/5-SM8 / -	BPK4-60L / -	BPK4-60L / -	BPK4-30L / -	BPK4-30L / -
Mains voltage ⁷⁾	1/N/PE AC 230 V 50 ... 60 Hz	1/N/PE AC 230 V 50 ... 60 Hz	1/N/PE AC 230 V 50 ... 60 Hz	1/N/PE AC 230 V 50 ... 60 Hz	1/N/PE AC 230 V 50 ... 60 Hz
Mains voltage toggleable ⁷⁾	1/N/PE AC 115 V 50 ... 60 Hz	1/N/PE AC 115 V 50 ... 60 Hz	1/N/PE AC 115 V 50 ... 60 Hz	1/N/PE AC 115 V 50 ... 60 Hz	1/N/PE AC 115 V 50 ... 60 Hz
Power consumption	75 VA	75 VA	75 VA	75 VA	75 VA
Noise max. ⁸⁾	60 dB(A)	60 dB(A)	60 dB(A)	60 dB(A)	60 dB(A)
Weight ca.	17.5 kg	17.5 kg	17.5 kg	17.5 kg	17.5 kg
Housing / 3D model ⁹⁾	19", 2 U / PLI_M6	19", 2 U / PLI_M8	19", 2 U / PLI_M8	19", 2 U / PLI_M7	19", 2 U / PLI_M7

1. Minimum voltage for maximum load current, linear derating to 0 V.
 2. Each current range of a higher voltage class in the same power class can be chosen as special current range.
 3. Level and duration of short-time power see diagram in technical data at page 53.
 4. The setting range reaches up to the short-time power.
 5. Rise and fall times are defined from 10 ... 90 % and 90 ... 10 % of maximum current at "fast" regulation speed (constant current mode, Tolerance ±20 %). Rise and fall time in „medium“ regulation speed: ca. 150 μs, „slow“: ca. 2 ms.
 6. Description of available terminals starting at page 109.
 7. Mains voltage tolerance: ±10 %
 8. Measured at the front in distance of 1 m.
 9. 1 U = 44.45 mm. Detailed dimensions by means of 3D models at www.hoercherl-hackl.com/downloads.

Model (Order number)	PLI3206	PLI3212	PLI3230	PLI3260	PLI3280
Maximum input voltage V _{max}	60 V	120 V	300 V	600 V	800 V
Minimum input voltage V _{min} ¹⁾	1 V	1.2 V	1.6 V	2 V	1.5 V
Maximum current I _{max} ²⁾	300 A	150 A	60 A	40 A	30 A
Continuous power	3,200 W	3,200 W	3,200 W	3,200 W	3,200 W
Short-time power ³⁾	6,400 W	6,400 W	4,800 W	3,200 W	3,200 W
Voltage setting	0 ... 60 V	0 ... 120 V	0 ... 300 V	0 ... 600 V	0 ... 800 V
Current setting	0 ... 300 A	0 ... 150 A	0 ... 60 A	0 ... 40 A	0 ... 30 A
Resistance setting	7 mΩ ... 2.15 Ω	14 mΩ ... 8.6 Ω	33 mΩ ... 53.7 Ω	50 mΩ ... 161 Ω	66.7 mΩ ... 286 Ω
Power setting ⁴⁾	0 ... 6,400 W	0 ... 6,400 W	0 ... 4,800 W	0 ... 3,200 W	0 ... 3,200 W
Rise/fall time ⁵⁾	20 μs	20 μs	20 μs	20 μs	20 μs
Input capacity ca.	8 μF	8 μF	8 μF	8 μF	8 μF
Load terminals ⁶⁾ rear / front	FKS25/8-SM10 / -	FKS25/8-SM10 with safety cover / -	BPK4-60L / -	BPK4-60L / -	BPK4-30L / -
Mains voltage ⁷⁾	1/N/PE AC 230 V 50 ... 60 Hz	1/N/PE AC 230 V 50 ... 60 Hz	1/N/PE AC 230 V 50 ... 60 Hz	1/N/PE AC 230 V 50 ... 60 Hz	1/N/PE AC 230 V 50 ... 60 Hz
Mains voltage toggleable ⁷⁾	1/N/PE AC 115 V 50 ... 60 Hz	1/N/PE AC 115 V 50 ... 60 Hz	1/N/PE AC 115 V 50 ... 60 Hz	1/N/PE AC 115 V 50 ... 60 Hz	1/N/PE AC 115 V 50 ... 60 Hz
Power consumption	140 VA	140 VA	140 VA	140 VA	140 VA
Noise max. ⁸⁾	70 dB(A)	70 dB(A)	70 dB(A)	70 dB(A)	70 dB(A)
Weight ca.	22.5 kg	22.5 kg	22.5 kg	20.5 kg	22.5 kg
Housing / 3D model ⁹⁾	19", 3 U / PLI_M12	19", 3 U / PLI_M12	19", 3 U / PLI_M8	19", 3 U / PLI_M14	19", 3 U / PLI_M13

Model (Order number)	PLI4806	PLI4812	PLI4230	PLI4260	PLI4280
Maximum input voltage V _{max}	60 V	120 V	300 V	600 V	800 V
Minimum input voltage V _{min} ¹⁾	1 V	1.2 V	2 V	1 V	2 V
Maximum current I _{max} ²⁾	450 A	225 A	90 A	60 A	45 A
Continuous power	4,800 W	4,800 W	4,200 W	4,200 W	4,200 W
Short-time power ³⁾	9,600 W	9,600 W	6,300 W	4,200 W	4,200 W
Voltage setting	0 ... 60 V	0 ... 120 V	0 ... 300 V	0 ... 600 V	0 ... 800 V
Current setting	0 ... 450 A	0 ... 225 A	0 ... 90 A	0 ... 60 A	0 ... 45 A
Resistance setting	5 mΩ ... 1.43 Ω	9 mΩ ... 5.73 Ω	23 mΩ ... 35.8 Ω	34 mΩ ... 107 Ω	45 mΩ ... 191 Ω
Power setting ⁴⁾	0 ... 9,600 W	0 ... 9,600 W	0 ... 6,300 W	0 ... 4,200 W	0 ... 4,200 W
Rise/fall time ⁵⁾	20 μs	20 μs	20 μs	20 μs	20 μs
Input capacity ca.	10 μF	10 μF	10 μF	10 μF	10 μF
Load terminals ⁶⁾ rear / front	FKS25/10-SM10 / -	FKS25/10-SM10 with safety cover / -	FKS25/10-SM10 with safety cover / -	FKS25/10-SM10 with safety cover / -	FKS25/10-SM10 with safety cover / -
Mains voltage ⁷⁾	1/N/PE AC 230 V 50 ... 60 Hz	1/N/PE AC 230 V 50 ... 60 Hz	1/N/PE AC 230 V 50 ... 60 Hz	1/N/PE AC 230 V 50 ... 60 Hz	1/N/PE AC 230 V 50 ... 60 Hz
Mains voltage toggleable ⁷⁾	1/N/PE AC 115 V 50 ... 60 Hz	1/N/PE AC 115 V 50 ... 60 Hz	1/N/PE AC 115 V 50 ... 60 Hz	1/N/PE AC 115 V 50 ... 60 Hz	1/N/PE AC 115 V 50 ... 60 Hz
Power consumption	190 VA	190 VA	190 VA	190 VA	190 VA
Noise max. ⁸⁾	71 dB(A)	71 dB(A)	71 dB(A)	71 dB(A)	71 dB(A)
Weight ca.	39 kg	39 kg	39 kg	38 kg	39 kg
Housing / 3D model ⁹⁾	19", 5 U / PLI_M19	19", 5 U / PLI_M19	19", 5 U / PLI_M19	19", 5 U / PLI_M19	19", 5 U / PLI_M19

1. Minimum voltage for maximum load current, linear derating to 0 V.
2. Each current range of a higher voltage class in the same power class can be chosen as special current range.
3. Level and duration of short-time power see diagram in technical data at page 53.
4. The setting range reaches up to the short-time power.
5. Rise and fall times are defined from 10 ... 90 % and 90 ... 10 % of maximum current at "fast" regulation speed (constant current mode, Tolerance ±20 %). Rise and fall time in „medium“ regulation speed: ca. 150 μs, „slow“: ca. 2 ms.
6. Description of available terminals starting at page 109.
7. Mains voltage tolerance: ±10 %
8. Measured at the front in distance of 1 m.
9. 1 U = 44.45 mm. Detailed dimensions by means of 3D models at www.hoechertl-hackl.com/downloads.

Model (Order number)	PLI6406	PLI6412	PLI5630	PLI5660	PLI5680
Maximum input voltage V _{max}	60 V	120 V	300 V	600 V	800 V
Minimum input voltage V _{min} ¹⁾	1.2 V	1.6 V	2 V	2 V	2 V
Maximum current I _{max} ²⁾	600 A	300 A	120 A	80 A	60 A
Continuous power	6,400 W	6,400 W	5,600 W	5,600 W	5,600 W
Short-time power ³⁾	12,800 W	12,800 W	8,400 W	5,600 W	5,600 W
Voltage setting	0 ... 60 V	0 ... 120 V	0 ... 300 V	0 ... 600 V	0 ... 800 V
Current setting	0 ... 600 A	0 ... 300 A	0 ... 120 A	0 ... 80 A	0 ... 60 A
Resistance setting	4 mΩ ... 1.07 Ω	7 mΩ ... 4.3 Ω	17 mΩ ... 26.8 Ω	25 mΩ ... 80.6 Ω	34 mΩ ... 143.3 Ω
Power setting ⁴⁾	0 ... 12,800 W	0 ... 12,800 W	0 ... 8,400 W	0 ... 5,600 W	0 ... 5,600 W
Rise/fall time ⁵⁾	20 μs	20 μs	20 μs	20 μs	20 μs
Input capacity ca.	14 μF	14 μF	12 μF	12 μF	12 μF
Load terminals ⁶⁾ rear / front	FKS40/12-SM12 / -	FKS25/10-SM10 with safety cover / -	FKS25/10-SM10 with safety cover / -	FKS25/10-SM10 with safety cover / -	FKS25/10-SM10 with safety cover / -
Mains voltage ⁷⁾	1/N/PE AC 230 V 50 ... 60 Hz	1/N/PE AC 230 V 50 ... 60 Hz	1/N/PE AC 230 V 50 ... 60 Hz	1/N/PE AC 230 V 50 ... 60 Hz	1/N/PE AC 230 V 50 ... 60 Hz
Mains voltage toggleable ⁷⁾	1/N/PE AC 115 V 50 ... 60 Hz	1/N/PE AC 115 V 50 ... 60 Hz	1/N/PE AC 115 V 50 ... 60 Hz	1/N/PE AC 115 V 50 ... 60 Hz	1/N/PE AC 115 V 50 ... 60 Hz
Power consumption	275 VA	275 VA	275 VA	275 VA	275 VA
Noise max. ⁸⁾	73 dB(A)	73 dB(A)	73 dB(A)	73 dB(A)	73 dB(A)
Weight ca.	56 kg	53 kg	56 kg	56 kg	56 kg
Housing / 3D model ⁹⁾	19", 8 U / PLI_M24	19", 8 U / PLI_M23	19", 8 U / PLI_M23	19", 8 U / PLI_M23	19", 8 U / PLI_M23

Model (Order number)	PLI8006	PLI8012	PLI7030	PLI7060	PLI7080
Maximum input voltage V _{max}	60 V	120 V	300 V	600 V	800 V
Minimum input voltage V _{min} ¹⁾	1 V	1.6 V	1.6 V	2 V	2 V
Maximum current I _{max} ²⁾	750 A	375 A	150 A	100 A	75 A
Continuous power	8,000 W	8,000 W	7,000 W	7,000 W	7,000 W
Short-time power ³⁾	16,000 W	16,000 W	10,500 W	7,000 W	7,000 W
Voltage setting	0 ... 60 V	0 ... 120 V	0 ... 300 V	0 ... 600 V	0 ... 800 V
Current setting	0 ... 750 A	0 ... 375 A	0 ... 150 A	0 ... 100 A	0 ... 75 A
Resistance setting	3 mΩ ... 0.86 Ω	6 mΩ ... 3.44 Ω	14 mΩ ... 21.5 Ω	20 mΩ ... 64.5 Ω	27 mΩ ... 114.7 Ω
Power setting ⁴⁾	0 ... 16,000 W	0 ... 16,000 W	0 ... 10,500 W	0 ... 7,000 W	0 ... 7,000 W
Rise/fall time ⁵⁾	20 μs	20 μs	20 μs	20 μs	20 μs
Input capacity ca.	16 μF	16 μF	14 μF	14 μF	14 μF
Load terminals ⁶⁾ rear / front	FKS40/12-SM12 / -	FKS25/10-SM10 with safety cover / -	FKS25/10-SM10 with safety cover / -	FKS25/10-SM10 with safety cover / -	FKS25/10-SM10 with safety cover / -
Mains voltage ⁷⁾	1/N/PE AC 230 V 50 ... 60 Hz	1/N/PE AC 230 V 50 ... 60 Hz	1/N/PE AC 230 V 50 ... 60 Hz	1/N/PE AC 230 V 50 ... 60 Hz	1/N/PE AC 230 V 50 ... 60 Hz
Mains voltage toggleable ⁷⁾	1/N/PE AC 115 V 50 ... 60 Hz	1/N/PE AC 115 V 50 ... 60 Hz	1/N/PE AC 115 V 50 ... 60 Hz	1/N/PE AC 115 V 50 ... 60 Hz	1/N/PE AC 115 V 50 ... 60 Hz
Power consumption	320 VA	320 VA	320 VA	320 VA	320 VA
Noise max. ⁸⁾	74 dB(A)	74 dB(A)	74 dB(A)	74 dB(A)	74 dB(A)
Weight ca.	57 kg	57 kg	57 kg	57 kg	57 kg
Housing / 3D model ⁹⁾	19", 8 U / PLI_M24	19", 8 U / PLI_M23	19", 8 U / PLI_M23	19", 8 U / PLI_M23	19", 8 U / PLI_M23

1. Minimum voltage for maximum load current, linear derating to 0 V.
 2. Each current range of a higher voltage class in the same power class can be chosen as special current range.
 3. Level and duration of short-time power see diagram in technical data at page 53.
 4. The setting range reaches up to the short-time power.
 5. Rise and fall times are defined from 10 ... 90 % and 90 ... 10 % of maximum current at "fast" regulation speed (constant current mode, Tolerance ±20 %). Rise and fall time in „medium“ regulation speed: ca. 150 μs, „slow“: ca. 2 ms.
 6. Description of available terminals starting at page 109.
 7. Mains voltage tolerance: ±10 %
 8. Measured at the front in distance of 1 m.
 9. 1 U = 44.45 mm. Detailed dimensions by means of 3D models at www.hoercherl-hackl.com/downloads.

Model (Order number)	PLI9606	PLI9612	PLI8430	PLI8460	PLI8480
Maximum input voltage V _{max}	60 V	120 V	300 V	600 V	800 V
Minimum input voltage V _{min} ¹⁾	1.2 V	1.6 V	2 V	2 V	2 V
Maximum current I _{max} ²⁾	900 A	450 A	180 A	120 A	90 A
Continuous power	9,600 W	9,600 W	8,400 W	8,400 W	8,400 W
Short-time power ³⁾	19,200 W	19,200 W	12,600 W	8,400 W	8,400 W
Voltage setting	0 ... 60 V	0 ... 120 V	0 ... 300 V	0 ... 600 V	0 ... 800 V
Current setting	0 ... 900 A	0 ... 450 A	0 ... 180 A	0 ... 120 A	0 ... 90 A
Resistance setting	3 mΩ ... 0.71 Ω	5 mΩ ... 2.86 Ω	12 mΩ ... 17.9 Ω	17 mΩ ... 53.7 Ω	23 mΩ ... 95.5 Ω
Power setting ⁴⁾	0 ... 19,200 W	0 ... 19,200 W	0 ... 12,600 W	0 ... 8,400 W	0 ... 8,400 W
Rise/fall time ⁵⁾	25 μs	20 μs	20 μs	20 μs	20 μs
Input capacity ca.	20 μF	20 μF	18 μF	18 μF	18 μF
Load terminals ⁶⁾ rear / front	FKS40/12-SM12 / -	FKS25/10-SM10 with safety cover / -	FKS25/10-SM10 with safety cover / -	FKS25/10-SM10 with safety cover / -	FKS25/10-SM10 with safety cover / -
Mains voltage ⁷⁾	1/N/PE AC 230 V 50 ... 60 Hz	1/N/PE AC 230 V 50 ... 60 Hz	1/N/PE AC 230 V 50 ... 60 Hz	1/N/PE AC 230 V 50 ... 60 Hz	1/N/PE AC 230 V 50 ... 60 Hz
Mains voltage toggleable ⁷⁾	1/N/PE AC 115 V 50 ... 60 Hz	1/N/PE AC 115 V 50 ... 60 Hz	1/N/PE AC 115 V 50 ... 60 Hz	1/N/PE AC 115 V 50 ... 60 Hz	1/N/PE AC 115 V 50 ... 60 Hz
Power consumption	380 VA	380 VA	380 VA	380 VA	380 VA
Noise max. ⁸⁾	74 dB(A)	74 dB(A)	74 dB(A)	74 dB(A)	74 dB(A)
Weight ca.	63 kg	63 kg	63 kg	63 kg	63 kg
Housing / 3D model ⁹⁾	19", 8 U / PLI_M24	19", 8 U / PLI_M23	19", 8 U / PLI_M23	19", 8 U / PLI_M23	19", 8 U / PLI_M23

Model (Order number)	PLI11206	PLI11212	PLI9830	PLI9860	PLI9880
Maximum input voltage V _{max}	60 V	120 V	300 V	600 V	800 V
Minimum input voltage V _{min} ¹⁾	1 V	1.2 V	2 V	2 V	2 V
Maximum current I _{max} ²⁾	1,050 A	525 A	210 A	140 A	105 A
Continuous power	11,200 W	11,200 W	9,800 W	9,800 W	9,800 W
Short-time power ³⁾	22,400 W	22,400 W	14,700 W	9,800 W	9,800 W
Voltage setting	0 ... 60 V	0 ... 120 V	0 ... 300 V	0 ... 600 V	0 ... 800 V
Current setting	0 ... 1,050 A	0 ... 525 A	0 ... 210 A	0 ... 140 A	0 ... 105 A
Resistance setting	2 mΩ ... 0.61 Ω	4 mΩ ... 2.45 Ω	10 mΩ ... 15.3 Ω	15 mΩ ... 46 Ω	19.1 mΩ ... 81.9 Ω
Power setting ⁴⁾	0 ... 22,400 W	0 ... 22,400 W	0 ... 14,700 W	0 ... 9,800 W	0 ... 9,800 W
Rise/fall time ⁵⁾	25 μs	20 μs	20 μs	20 μs	20 μs
Input capacity ca.	24 μF	24 μF	20 μF	20 μF	20 μF
Load terminals ⁶⁾ rear / front	FKS40/12-SM12 / -	FKS40/12-SM12 with safety cover / -	FKS25/10-SM10 with safety cover / -	FKS25/10-SM10 with safety cover / -	FKS25/10-SM10 with safety cover / -
Mains voltage ⁷⁾	1/N/PE AC 230 V 50 ... 60 Hz	1/N/PE AC 230 V 50 ... 60 Hz	1/N/PE AC 230 V 50 ... 60 Hz	1/N/PE AC 230 V 50 ... 60 Hz	1/N/PE AC 230 V 50 ... 60 Hz
Mains voltage toggleable ⁷⁾	1/N/PE AC 115 V 50 ... 60 Hz	1/N/PE AC 115 V 50 ... 60 Hz	1/N/PE AC 115 V 50 ... 60 Hz	1/N/PE AC 115 V 50 ... 60 Hz	1/N/PE AC 115 V 50 ... 60 Hz
Power consumption	450 VA	450 VA	450 VA	450 VA	450 VA
Noise max. ⁸⁾	75 dB(A)	75 dB(A)	75 dB(A)	75 dB(A)	75 dB(A)
Weight ca.	80 kg	80 kg	80 kg	74 kg	74 kg
Housing / 3D model ⁹⁾	19", 11 U / PLI_M28	19", 11 U / PLI_M28	19", 11 U / PLI_M27	19", 11 U / PLI_M27	19", 11 U / PLI_M27

1. Minimum voltage for maximum load current, linear derating to 0 V.
2. Each current range of a higher voltage class in the same power class can be chosen as special current range.
3. Level and duration of short-time power see diagram in technical data at page 53.
4. The setting range reaches up to the short-time power.
5. Rise and fall times are defined from 10 ... 90 % and 90 ... 10 % of maximum current at "fast" regulation speed (constant current mode, Tolerance ±20 %). Rise and fall time in „medium“ regulation speed: ca. 150 μs, „slow“: ca. 2 ms.
6. Description of available terminals starting at page 109.
7. Mains voltage tolerance: ±10 %
8. Measured at the front in distance of 1 m.
9. 1 U = 44.45 mm. Detailed dimensions by means of 3D models at www.hoecherl-hackl.com/downloads.

Model (Order number)	PLI12806	PLI12812	PLI11230	PLI11260	PLI11280
Maximum input voltage V _{max}	60 V	120 V	300 V	600 V	800 V
Minimum input voltage V _{min} ¹⁾	1 V	1.2 V	2 V	1 V	2 V
Maximum current I _{max} ²⁾	1,200 A	600 A	240 A	160 A	120 A
Continuous power	12,800 W	12,800 W	11,200 W	11,200 W	11,200 W
Short-time power ³⁾	25,600 W	25,600 W	16,800 W	11,200 W	11,200 W
Voltage setting	0 ... 60 V	0 ... 120 V	0 ... 300 V	0 ... 600 V	0 ... 800 V
Current setting	0 ... 1,200 A	0 ... 600 A	0 ... 240 A	0 ... 160 A	0 ... 120 A
Resistance setting	2 mΩ ... 0.53 Ω	4 mΩ ... 2.15 Ω	9 mΩ ... 13.4 Ω	13 mΩ ... 40.3 Ω	17 mΩ ... 71.6 Ω
Power setting ⁴⁾	0 ... 25,600 W	0 ... 25,600 W	0 ... 16,800 W	0 ... 11,200 W	0 ... 11,200 W
Rise/fall time ⁵⁾	25 μs	20 μs	20 μs	20 μs	20 μs
Input capacity ca.	26 μF	26 μF	24 μF	24 μF	26 μF
Load terminals ⁶⁾ rear / front	FKS40/12-SM12 / -	FKS40/12-SM12 with safety cover / -	FKS25/10-SM10 with safety cover / -	FKS25/10-SM10 with safety cover / -	FKS25/10-SM10 with safety cover / -
Mains voltage ⁷⁾	1/N/PE AC 230 V 50 ... 60 Hz	1/N/PE AC 230 V 50 ... 60 Hz	1/N/PE AC 230 V 50 ... 60 Hz	1/N/PE AC 230 V 50 ... 60 Hz	1/N/PE AC 230 V 50 ... 60 Hz
Mains voltage toggleable ⁷⁾	1/N/PE AC 115 V 50 ... 60 Hz	1/N/PE AC 115 V 50 ... 60 Hz	1/N/PE AC 115 V 50 ... 60 Hz	1/N/PE AC 115 V 50 ... 60 Hz	1/N/PE AC 115 V 50 ... 60 Hz
Power consumption	500 VA	500 VA	500 VA	500 VA	500 VA
Noise max. ⁸⁾	76 dB(A)	76 dB(A)	76 dB(A)	76 dB(A)	76 dB(A)
Weight ca.	82 kg	82 kg	82 kg	82 kg	82 kg
Housing / 3D model ⁹⁾	19", 11 U / PLI_M28	19", 11 U / PLI_M28	19", 11 U / PLI_M27	19", 11 U / PLI_M27	19", 11 U / PLI_M27

Model (Order number)	PLI14406	PLI14412	PLI12630	PLI12660	PLI12680
Maximum input voltage V _{max}	60 V	120 V	300 V	600 V	800 V
Minimum input voltage V _{min} ¹⁾	1 V	1.2 V	1.4 V	2 V	2 V
Maximum current I _{max} ²⁾	1,350 A	675 A	270 A	180 A	135 A
Continuous power	14,400 W	14,400 W	12,600 W	12,600 W	12,600 W
Short-time power ³⁾	28,800 W	28,800 W	18,900 W	12,600 W	12,600 W
Voltage setting	0 ... 60 V	0 ... 120 V	0 ... 300 V	0 ... 600 V	0 ... 800 V
Current setting	0 ... 1,350 A	0 ... 675 A	0 ... 270 A	0 ... 180 A	0 ... 135 A
Resistance setting	2 mΩ ... 477 mΩ	3 mΩ ... 1.91 Ω	8 mΩ ... 11.9 Ω	12 mΩ ... 35.8 Ω	15 mΩ ... 63.7 Ω
Power setting ⁴⁾	0 ... 28,800 W	0 ... 28,800 W	0 ... 18,900 W	0 ... 12,600 W	0 ... 12,600 W
Rise/fall time ⁵⁾	30 μs	20 μs	20 μs	20 μs	20 μs
Input capacity ca.	30 μF	30 μF	26 μF	26 μF	26 μF
Load terminals ⁶⁾ rear / front	FKS40/12-SM12 / -	FKS40/12-SM12 with safety cover / -	FKS25/10-SM10 with safety cover / -	FKS25/10-SM10 with safety cover / -	FKS25/10-SM10 with safety cover / -
Mains voltage ⁷⁾	1/N/PE AC 230 V 50 ... 60 Hz	1/N/PE AC 230 V 50 ... 60 Hz	1/N/PE AC 230 V 50 ... 60 Hz	1/N/PE AC 230 V 50 ... 60 Hz	1/N/PE AC 230 V 50 ... 60 Hz
Mains voltage toggleable ⁷⁾	1/N/PE AC 115 V 50 ... 60 Hz	1/N/PE AC 115 V 50 ... 60 Hz	1/N/PE AC 115 V 50 ... 60 Hz	1/N/PE AC 115 V 50 ... 60 Hz	1/N/PE AC 115 V 50 ... 60 Hz
Power consumption	540 VA	540 VA	540 VA	540 VA	540 VA
Noise max. ⁸⁾	76 dB(A)	76 dB(A)	76 dB(A)	76 dB(A)	76 dB(A)
Weight ca.	89 kg	87 kg	85 kg	84 kg	89 kg
Housing / 3D model ⁹⁾	19", 11 U / PLI_M28	19", 11 U / PLI_M28	19", 11 U / PLI_M27	19", 11 U / PLI_M27	19", 11 U / PLI_M27

1. Minimum voltage for maximum load current, linear derating to 0 V.
2. Each current range of a higher voltage class in the same power class can be chosen as special current range.
3. Level and duration of short-time power see diagram in technical data at page 53.
4. The setting range reaches up to the short-time power.
5. Rise and fall times are defined from 10 ... 90 % and 90 ... 10 % of maximum current at "fast" regulation speed (constant current mode, Tolerance ±20 %). Rise and fall time in „medium“ regulation speed: ca. 150 μs, „slow“: ca. 2 ms.
6. Description of available terminals starting at page 109.
7. Mains voltage tolerance: ±10 %
8. Measured at the front in distance of 1 m.
9. 1 U = 44.45 mm. Detailed dimensions by means of 3D models at www.hoercherl-hackl.com/downloads.

Model (Order number)	PLI16006	PLI16012	PLI14030	PLI14060	PLI14080
Maximum input voltage V _{max}	60 V	120 V	300 V	600 V	800 V
Minimum input voltage V _{min} ¹⁾	1.2 V	1.4 V	2 V	2 V	2 V
Maximum current I _{max} ²⁾	1,500 A	750 A	300 A	200 A	150 A
Continuous power	16,000 W	16,000 W	14,000 W	14,000 W	14,000 W
Short-time power ³⁾	32,000 W	32,000 W	21,000 W	14,000 W	14,000 W
Voltage setting	0 ... 60 V	0 ... 120 V	0 ... 300 V	0 ... 600 V	0 ... 800 V
Current setting	0 ... 1.500 A	0 ... 750 A	0 ... 300 A	0 ... 200 A	0 ... 150 A
Resistance setting	2 mΩ ... 0.430 Ω	3 mΩ ... 1.72 Ω	7 mΩ ... 10.7 Ω	10 mΩ ... 32.2 Ω	14 mΩ ... 57.3 Ω
Power setting ⁴⁾	0 ... 32,000 W	0 ... 32,000 W	0 ... 21,000 W	0 ... 14,000 W	0 ... 14,000 W
Rise/fall time ⁵⁾	30 μs	20 μs	25 μs	20 μs	20 μs
Input capacity ca.	32 μF	32 μF	26 μF	26 μF	26 μF
Load terminals ⁶⁾ rear / front	FKS40/12-SM12 / -	FKS40/12-SM12 with safety cover / -	FKS25/10-SM10 with safety cover / -	FKS25/10-SM10 with safety cover / -	FKS25/10-SM10 with safety cover / -
Mains voltage ⁷⁾	1/N/PE AC 230 V 50 ... 60 Hz	1/N/PE AC 230 V 50 ... 60 Hz	1/N/PE AC 230 V 50 ... 60 Hz	1/N/PE AC 230 V 50 ... 60 Hz	1/N/PE AC 230 V 50 ... 60 Hz
Mains voltage toggleable ⁷⁾	1/N/PE AC 115 V 50 ... 60 Hz	1/N/PE AC 115 V 50 ... 60 Hz	1/N/PE AC 115 V 50 ... 60 Hz	1/N/PE AC 115 V 50 ... 60 Hz	1/N/PE AC 115 V 50 ... 60 Hz
Power consumption	600 VA	600 VA	600 VA	600 VA	600 VA
Noise max. ⁸⁾	77 dB(A)	77 dB(A)	77 dB(A)	77 dB(A)	77 dB(A)
Weight ca.	104 kg	104 kg	104 kg	104 kg	104 kg
Housing / 3D model ⁹⁾	19", 14 U / PLI_M32	19", 14 U / PLI_M32	19", 14 U / PLI_M31	19", 14 U / PLI_M31	19", 14 U / PLI_M31

Model (Order number)	PLI17606	PLI17612	PLI15430	PLI15460	PLI15480
Maximum input voltage V _{max}	60 V	120 V	300 V	600 V	800 V
Minimum input voltage V _{min} ¹⁾	1 V	1.4 V	2 V	1.2 V	2 V
Maximum current I _{max} ²⁾	1,650 A	825 A	330 A	220 A	165 A
Continuous power	17,600 W	17,600 W	15,400 W	15,400 W	15,400 W
Short-time power ³⁾	35,200 W	35,200 W	23,100 W	15,400 W	15,400 W
Voltage setting	0 ... 60 V	0 ... 120 V	0 ... 300 V	0 ... 600 V	0 ... 800 V
Current setting	0 ... 1,650 A	0 ... 825 A	0 ... 330 A	0 ... 220 A	0 ... 165 A
Resistance setting	2 mΩ ... 0.391 Ω	3 mΩ ... 1.56 Ω	7 mΩ ... 9.77 Ω	10 mΩ ... 29.3 Ω	13 mΩ ... 52.1 Ω
Power setting ⁴⁾	0 ... 35,200 W	0 ... 35,200 W	0 ... 23,100 W	0 ... 15,400 W	0 ... 15,400 W
Rise/fall time ⁵⁾	30 μs	20 μs	25 μs	20 μs	20 μs
Input capacity ca.	36 μF	36 μF	32 μF	32 μF	32 μF
Load terminals ⁶⁾ rear / front	FKS40/12-SM12 / -	FKS40/12-SM12 with safety cover / -	FKS25/10-SM10 with safety cover / -	FKS25/10-SM10 with safety cover / -	FKS25/10-SM10 with safety cover / -
Mains voltage ⁷⁾	1/N/PE AC 230 V 50 ... 60 Hz	1/N/PE AC 230 V 50 ... 60 Hz	1/N/PE AC 230 V 50 ... 60 Hz	1/N/PE AC 230 V 50 ... 60 Hz	1/N/PE AC 230 V 50 ... 60 Hz
Mains voltage toggleable ⁷⁾	1/N/PE AC 115 V 50 ... 60 Hz	1/N/PE AC 115 V 50 ... 60 Hz	1/N/PE AC 115 V 50 ... 60 Hz	1/N/PE AC 115 V 50 ... 60 Hz	1/N/PE AC 115 V 50 ... 60 Hz
Power consumption	675 VA	675 VA	675 VA	675 VA	675 VA
Noise max. ⁸⁾	77 dB(A)	77 dB(A)	77 dB(A)	77 dB(A)	77 dB(A)
Weight ca.	105 kg	106 kg	105 kg	98 kg	105 kg
Housing / 3D model ⁹⁾	19", 14 U / PLI_M32	19", 14 U / PLI_M32	19", 14 U / PLI_M31	19", 14 U / PLI_M31	19", 14 U / PLI_M31

1. Minimum voltage for maximum load current, linear derating to 0 V.
2. Each current range of a higher voltage class in the same power class can be chosen as special current range.
3. Level and duration of short-time power see diagram in technical data at page 53.
4. The setting range reaches up to the short-time power.
5. Rise and fall times are defined from 10 ... 90 % and 90 ... 10 % of maximum current at "fast" regulation speed (constant current mode, Tolerance ±20 %). Rise and fall time in „medium“ regulation speed: ca. 150 μs, „slow“: ca. 2 ms.
6. Description of available terminals starting at page 109.
7. Mains voltage tolerance: ±10 %
8. Measured at the front in distance of 1 m.
9. 1 U = 44.45 mm. Detailed dimensions by means of 3D models at www.hoerchl-hackl.com/downloads.

Model (Order number)	PLI19206	PLI19212	PLI16830	PLI16860	PLI16880
Maximum input voltage V _{max}	60 V	120 V	300 V	600 V	800 V
Minimum input voltage V _{min} ¹⁾	1.2 V	1.2 V	2 V	2 V	2 V
Maximum current I _{max} ²⁾	1,800 A	900 A	360 A	240 A	180 A
Continuous power	19,200 W	19,200 W	16,800 W	16,800 W	16,800 W
Short-time power ³⁾	38,400 W	38,400 W	25,200 W	16,800 W	16,800 W
Voltage setting	0 ... 60 V	0 ... 120 V	0 ... 300 V	0 ... 600 V	0 ... 800 V
Current setting	0 ... 1,800 A	0 ... 900 A	0 ... 360 A	0 ... 240 A	0 ... 180 A
Resistance setting	2 mΩ ... 0.358 Ω	3 mΩ ... 1.43 Ω	6 mΩ ... 8.96 Ω	9 mΩ ... 26.88 Ω	12 mΩ ... 47.7 Ω
Power setting ⁴⁾	0 ... 38,400 W	0 ... 38,400 W	0 ... 25,200 W	0 ... 16,800 W	0 ... 16,800 W
Rise/fall time ⁵⁾	30 μs	30 μs	25 μs	20 μs	20 μs
Input capacity ca.	40 μF	40 μF	34 μF	34 μF	34 μF
Load terminals ⁶⁾ rear / front	FKS40/12-SM12 / -	FKS40/12-SM12 with safety cover / -	FKS25/10-SM10 with safety cover / -	FKS25/10-SM10 with safety cover / -	FKS25/10-SM10 with safety cover / -
Mains voltage ⁷⁾	1/N/PE AC 230 V 50 ... 60 Hz	1/N/PE AC 230 V 50 ... 60 Hz	1/N/PE AC 230 V 50 ... 60 Hz	1/N/PE AC 230 V 50 ... 60 Hz	1/N/PE AC 230 V 50 ... 60 Hz
Mains voltage toggleable ⁷⁾	1/N/PE AC 115 V 50 ... 60 Hz	1/N/PE AC 115 V 50 ... 60 Hz	1/N/PE AC 115 V 50 ... 60 Hz	1/N/PE AC 115 V 50 ... 60 Hz	1/N/PE AC 115 V 50 ... 60 Hz
Power consumption	700 VA	700 VA	700 VA	700 VA	700 VA
Noise max. ⁸⁾	77 dB(A)	77 dB(A)	77 dB(A)	77 dB(A)	77 dB(A)
Weight ca.	112 kg	112 kg	112 kg	112 kg	112 kg
Housing / 3D model ⁹⁾	19", 14 U / PLI_M32	19", 14 U / PLI_M32	19", 14 U / PLI_M31	19", 14 U / PLI_M31	19", 14 U / PLI_M31

Model (Order number)	PLI20806	PLI20812	PLI18230	PLI18260	PLI18280
Maximum input voltage V _{max}	60 V	120 V	300 V	600 V	800 V
Minimum input voltage V _{min} ¹⁾	1.2 V	1.2 V	2 V	2 V	2 V
Maximum current I _{max} ²⁾	1,950 A	975 A	390 A	260 A	195 A
Continuous power	20,800 W	20,800 W	18,200 W	18,200 W	18,200 W
Short-time power ³⁾	41,600 W	41,600 W	27,300 W	18,200 W	18,200 W
Voltage setting	0 ... 60 V	0 ... 120 V	0 ... 300 V	0 ... 600 V	0 ... 800 V
Current setting	0 ... 1,950 A	0 ... 975 A	0 ... 390 A	0 ... 260 A	0 ... 195 A
Resistance setting	2 mΩ ... 0.33 Ω	3 mΩ ... 1.32 Ω	6 mΩ ... 8.27 Ω	8 mΩ ... 24.8 Ω	11 mΩ ... 44.1 Ω
Power setting ⁴⁾	0 ... 41,600 W	0 ... 41,600 W	0 ... 27,300 W	0 ... 18,200 W	0 ... 18,200 W
Rise/fall time ⁵⁾	30 μs	30 μs	25 μs	25 μs	20 μs
Input capacity ca.	42 μF	42 μF	38 μF	38 μF	38 μF
Load terminals ⁶⁾ rear / front	FKS40/12-SM12 / -	FKS40/12-SM12 with safety cover / -	FKS25/10-SM10 with safety cover / -	FKS25/10-SM10 with safety cover / -	FKS25/10-SM10 with safety cover / -
Mains voltage ⁷⁾	1/N/PE AC 230 V 50 ... 60 Hz	1/N/PE AC 230 V 50 ... 60 Hz	1/N/PE AC 230 V 50 ... 60 Hz	1/N/PE AC 230 V 50 ... 60 Hz	1/N/PE AC 230 V 50 ... 60 Hz
Mains voltage toggleable ⁷⁾	1/N/PE AC 115 V 50 ... 60 Hz	1/N/PE AC 115 V 50 ... 60 Hz	1/N/PE AC 115 V 50 ... 60 Hz	1/N/PE AC 115 V 50 ... 60 Hz	1/N/PE AC 115 V 50 ... 60 Hz
Power consumption	770 VA	770 VA	770 VA	770 VA	770 VA
Noise max. ⁸⁾	77 dB(A)	77 dB(A)	77 dB(A)	77 dB(A)	77 dB(A)
Weight ca.	126 kg	126 kg	118 kg	126 kg	126 kg
Housing / 3D model ⁹⁾	19", 17 U / PLI_M36	19", 17 U / PLI_M36	19", 17 U / PLI_M35	19", 17 U / PLI_M35	19", 17 U / PLI_M35

1. Minimum voltage for maximum load current, linear derating to 0 V.
2. Each current range of a higher voltage class in the same power class can be chosen as special current range.
3. Level and duration of short-time power see diagram in technical data at page 53.
4. The setting range reaches up to the short-time power.
5. Rise and fall times are defined from 10 ... 90 % and 90 ... 10 % of maximum current at "fast" regulation speed (constant current mode, Tolerance ±20 %). Rise and fall time in „medium“ regulation speed: ca. 150 μs, „slow“: ca. 2 ms.
6. Description of available terminals starting at page 109.
7. Mains voltage tolerance: ±10 %
8. Measured at the front in distance of 1 m.
9. 1 U = 44.45 mm. Detailed dimensions by means of 3D models at www.hoecherl-hackl.com/downloads.

Model (Order number)	PLI22406	PLI22412	PLI19630	PLI19660	PLI19680
Maximum input voltage V _{max}	60 V	120 V	300 V	600 V	800 V
Minimum input voltage V _{min} ¹⁾	1.2 V	1.2 V	2 V	2 V	2 V
Maximum current I _{max} ²⁾	2,100 A	1,050 A	420 A	280 A	210 A
Continuous power	22,400 W	22,400 W	19,600 W	19,600 W	19,600 W
Short-time power ³⁾	44,800 W	44,800 W	29,400 W	19,600 W	19,600 W
Voltage setting	0 ... 60 V	0 ... 120 V	0 ... 300 V	0 ... 600 V	0 ... 800 V
Current setting	0 ... 2,100 A	0 ... 1050 A	0 ... 420 A	0 ... 280 A	0 ... 210 A
Resistance setting	1 mΩ ... 0.30 Ω	2 mΩ ... 1.22 Ω	5 mΩ ... 7.68 Ω	8 mΩ ... 23 Ω	10 mΩ ... 40.9 Ω
Power setting ⁴⁾	0 ... 44,800 W	0 ... 44,800 W	0 ... 29,400 W	0 ... 19,600 W	0 ... 19,600 W
Rise/fall time ⁵⁾	30 μs	30 μs	25 μs	25 μs	20 μs
Input capacity ca.	46 μF	46 μF	40 μF	40 μF	40 μF
Load terminals ⁶⁾ rear / front	FKS40/12-SM12 / -	FKS40/12-SM12 with safety cover / -	FKS25/10-SM10 with safety cover / -	FKS25/10-SM10 with safety cover / -	FKS25/10-SM10 with safety cover / -
Mains voltage ⁷⁾	1/N/PE AC 230 V 50 ... 60 Hz	1/N/PE AC 230 V 50 ... 60 Hz	1/N/PE AC 230 V 50 ... 60 Hz	1/N/PE AC 230 V 50 ... 60 Hz	1/N/PE AC 230 V 50 ... 60 Hz
Mains voltage toggleable ⁷⁾	1/N/PE AC 115 V 50 ... 60 Hz	1/N/PE AC 115 V 50 ... 60 Hz	1/N/PE AC 115 V 50 ... 60 Hz	1/N/PE AC 115 V 50 ... 60 Hz	1/N/PE AC 115 V 50 ... 60 Hz
Power consumption	810 VA	870 VA	870 VA	870 VA	870 VA
Noise max. ⁸⁾	78 dB(A)	78 dB(A)	78 dB(A)	78 dB(A)	78 dB(A)
Weight ca.	131 kg	131 kg	124 kg	131 kg	131 kg
Housing / 3D model ⁹⁾	19", 17 U / PLI_M36	19", 17 U / PLI_M36	19", 17 U / PLI_M35	19", 17 U / PLI_M35	19", 17 U / PLI_M35

Model (Order number)	PLI24006	PLI24012	PLI21030	PLI21060	PLI21080
Maximum input voltage V _{max}	60 V	120 V	300 V	600 V	800 V
Minimum input voltage V _{min} ¹⁾	1.2 V	1.2 V	2 V	2 V	2 V
Maximum current I _{max} ²⁾	2,250 A	1,125 A	450 A	300 A	225 A
Continuous power	24,000 W	24,000 W	21,000 W	21,000 W	21,000 W
Short-time power ³⁾	48,000 W	48,000 W	31,500 W	21,000 W	21,000 W
Voltage setting	0 ... 60 V	0 ... 120 V	0 ... 300 V	0 ... 600 V	0 ... 800 V
Current setting	0 ... 2,250 A	0 ... 1,125 A	0 ... 450 A	0 ... 300 A	0 ... 225 A
Resistance setting	1 mΩ ... 0.28 Ω	2 mΩ ... 1.14 Ω	5 mΩ ... 7.16 Ω	7 mΩ ... 21.5 Ω	9 mΩ ... 38.2 Ω
Power setting ⁴⁾	0 ... 48,000 W	0 ... 48,000 W	0 ... 31,500 W	0 ... 21,000 W	0 ... 21,000 W
Rise/fall time ⁵⁾	35 μs	30 μs	25 μs	25 μs	20 μs
Input capacity ca.	48 μF	48 μF	42 μF	42 μF	42 μF
Load terminals ⁶⁾ rear / front	FKS40/12-SM12 / -	FKS40/12-SM12 with safety cover / -	FKS25/10-SM10 with safety cover / -	FKS25/10-SM10 with safety cover / -	FKS25/10-SM10 with safety cover / -
Mains voltage ⁷⁾	1/N/PE AC 230 V 50 ... 60 Hz	1/N/PE AC 230 V 50 ... 60 Hz	1/N/PE AC 230 V 50 ... 60 Hz	1/N/PE AC 230 V 50 ... 60 Hz	1/N/PE AC 230 V 50 ... 60 Hz
Mains voltage toggleable ⁷⁾	1/N/PE AC 115 V 50 ... 60 Hz	1/N/PE AC 115 V 50 ... 60 Hz	1/N/PE AC 115 V 50 ... 60 Hz	1/N/PE AC 115 V 50 ... 60 Hz	1/N/PE AC 115 V 50 ... 60 Hz
Power consumption	875 VA	875 VA	875 VA	875 VA	875 VA
Noise max. ⁸⁾	78 dB(A)	78 dB(A)	78 dB(A)	78 dB(A)	78 dB(A)
Weight ca.	136 kg	136 kg	136 kg	136 kg	130 kg
Housing / 3D model ⁹⁾	19", 17 U / PLI_M36	19", 17 U / PLI_M36	19", 17 U / PLI_M35	19", 17 U / PLI_M35	19", 17 U / PLI_M35

1. Minimum voltage for maximum load current, linear derating to 0 V.
2. Each current range of a higher voltage class in the same power class can be chosen as special current range.
3. Level and duration of short-time power see diagram in technical data at page 53.
4. The setting range reaches up to the short-time power.
5. Rise and fall times are defined from 10 ... 90 % and 90 ... 10 % of maximum current at "fast" regulation speed (constant current mode, Tolerance ±20 %). Rise and fall time in „medium“ regulation speed: ca. 150 μs, „slow“: ca. 2 ms.
6. Description of available terminals starting at page 109.
7. Mains voltage tolerance: ±10 %
8. Measured at the front in distance of 1 m.
9. 1 U = 44.45 mm. Detailed dimensions by means of 3D models at www.hoerchl-hackl.com/downloads.

Model (Order number)	PLI25606	PLI25612	PLI22430	PLI22460	PLI22480
Maximum input voltage V _{max}	60 V	120 V	300 V	600 V	800 V
Minimum input voltage V _{min} ¹⁾	1.2 V	1.2 V	2 V	2 V	2 V
Maximum current I _{max} ²⁾	2,400 A	1,200 A	480 A	320 A	240 A
Continuous power	25,600 W	25,600 W	22,400 W	22,400 W	22,400 W
Short-time power ³⁾	51,200 W	51,200 W	33,600 W	22,400 W	22,400 W
Voltage setting	0 ... 60 V	0 ... 120 V	0 ... 300 V	0 ... 600 V	0 ... 800 V
Current setting	0 ... 2,400 A	0 ... 1,200 A	0 ... 480 A	0 ... 320 A	0 ... 240 A
Resistance setting	1 mΩ ... 0.26 Ω	2 mΩ ... 1.07 Ω	5 mΩ ... 6.72 Ω	7 mΩ ... 20.1 Ω	9 mΩ ... 35.8 Ω
Power setting ⁴⁾	0 ... 51,200 W	0 ... 51,200 W	0 ... 33,600 W	0 ... 22,400 W	0 ... 22,400 W
Rise/fall time ⁵⁾	35 μs	30 μs	30 μs	25 μs	30 μs
Input capacity ca.	52 μF	52 μF	46 μF	46 μF	46 μF
Load terminals ⁶⁾ rear / front	FKS40/12-SM12 -	FKS40/12-SM12 with safety cover / -	FKS25/10-SM10 with safety cover / -	FKS25/10-SM10 with safety cover / -	FKS25/10-SM10 with safety cover / -
Mains voltage ⁷⁾	1/N/PE AC 230 V 50 ... 60 Hz	1/N/PE AC 230 V 50 ... 60 Hz	1/N/PE AC 230 V 50 ... 60 Hz	1/N/PE AC 230 V 50 ... 60 Hz	1/N/PE AC 230 V 50 ... 60 Hz
Mains voltage toggleable ⁷⁾	1/N/PE AC 115 V 50 ... 60 Hz	1/N/PE AC 115 V 50 ... 60 Hz	1/N/PE AC 115 V 50 ... 60 Hz	1/N/PE AC 115 V 50 ... 60 Hz	1/N/PE AC 115 V 50 ... 60 Hz
Power consumption	900 VA	900 VA	900 VA	900 VA	900 VA
Noise max. ⁸⁾	80 dB(A)	80 dB(A)	80 dB(A)	80 dB(A)	80 dB(A)
Weight ca.	142 kg	142 kg	142 kg	142 kg	142 kg
Housing / 3D model ⁹⁾	19", 20 U / PLI_M40	19", 20 U / PLI_M40	19", 20 U / PLI_M39	19", 20 U / PLI_M39	19", 20 U / PLI_M39

Model (Order number)	PLI27206	PLI27212	PLI23830	PLI23860	PLI23880
Maximum input voltage V _{max}	60 V	120 V	300 V	600 V	800 V
Minimum input voltage V _{min} ¹⁾	1.2 V	1.2 V	2 V	2 V	2 V
Maximum current I _{max} ²⁾	2,550 A	1,275 A	510 A	340 A	255 A
Continuous power	27,200 W	27,200 W	23,800 W	23,800 W	23,800 W
Short-time power ³⁾	54,400 W	54,400 W	35,700 W	23,800 W	23,800 W
Voltage setting	0 ... 60 V	0 ... 120 V	0 ... 300 V	0 ... 600 V	0 ... 800 V
Current setting	0 ... 2,550 A	0 ... 1,275 A	0 ... 510 A	0 ... 340 A	0 ... 255 A
Resistance setting	1 mΩ ... 0.25 Ω	2 mΩ ... 1.01 Ω	4 mΩ ... 6.32 Ω	6 mΩ ... 18.9 Ω	8 mΩ ... 33.7 Ω
Power setting ⁴⁾	0 ... 54,400 W	0 ... 54,400 W	0 ... 35,700 W	0 ... 23,800 W	0 ... 23,800 W
Rise/fall time ⁵⁾	35 μs	30 μs	30 μs	25 μs	30 μs
Input capacity ca.	56 μF	56 μF	48 μF	48 μF	48 μF
Load terminals ⁶⁾ rear / front	FKS40/12-SM12 / -	FKS40/12-SM12 with safety cover / -	FKS40/12-SM12 with safety cover / -	FKS25/10-SM10 with safety cover / -	FKS25/10-SM10 with safety cover / -
Mains voltage ⁷⁾	1/N/PE AC 230 V 50 ... 60 Hz	1/N/PE AC 230 V 50 ... 60 Hz	1/N/PE AC 230 V 50 ... 60 Hz	1/N/PE AC 230 V 50 ... 60 Hz	1/N/PE AC 230 V 50 ... 60 Hz
Mains voltage toggleable ⁷⁾	1/N/PE AC 115 V 50 ... 60 Hz	1/N/PE AC 115 V 50 ... 60 Hz	1/N/PE AC 115 V 50 ... 60 Hz	1/N/PE AC 115 V 50 ... 60 Hz	1/N/PE AC 115 V 50 ... 60 Hz
Power consumption	1,000 VA	1,000 VA	1,000 VA	1,000 VA	1,000 VA
Noise max. ⁸⁾	80 dB(A)	80 dB(A)	80 dB(A)	80 dB(A)	80 dB(A)
Weight ca.	152 kg	152 kg	152 kg	152 kg	152 kg
Housing / 3D model ⁹⁾	19", 20 U / PLI_M40	19", 20 U / PLI_M40	19", 20 U / PLI_M40	19", 20 U / PLI_M39	19", 20 U / PLI_M39

1. Minimum voltage for maximum load current, linear derating to 0 V.
 2. Each current range of a higher voltage class in the same power class can be chosen as special current range.
 3. Level and duration of short-time power see diagram in technical data at page 53.
 4. The setting range reaches up to the short-time power.
 5. Rise and fall times are defined from 10 ... 90 % and 90 ... 10 % of maximum current at "fast" regulation speed (constant current mode, Tolerance ±20 %). Rise and fall time in „medium“ regulation speed: ca. 150 μs, „slow“: ca. 2 ms.
 6. Description of available terminals starting at page 109.
 7. Mains voltage tolerance: ±10 %
 8. Measured at the front in distance of 1 m.
 9. 1 U = 44.45 mm. Detailed dimensions by means of 3D models at www.hoerchl-hackl.com/downloads.

Model (Order number)	PLI28806	PLI28812	PLI25230	PLI25260	PLI25280
Maximum input voltage V _{max}	60 V	120 V	300 V	600 V	800 V
Minimum input voltage V _{min} ¹⁾	1.2 V	1.2 V	2 V	2 V	2 V
Maximum current I _{max} ²⁾	2,700 A	1,350 A	540 A	360 A	270 A
Continuous power	28,800 W	28,800 W	25,200 W	25,200 W	25,200 W
Short-time power ³⁾	57,600 W	57,600 W	37,800 W	25,200 W	25,200 W
Voltage setting	0 ... 60 V	0 ... 120 V	0 ... 300 V	0 ... 600 V	0 ... 800 V
Current setting	0 ... 2,700 A	0 ... 1,350 A	0 ... 540 A	0 ... 360 A	0 ... 270 A
Resistance setting	1 mΩ ... 0.23 Ω	2 mΩ ... 0.95 Ω	4 mΩ ... 5.97 Ω	6 mΩ ... 17.9 Ω	8 mΩ ... 31.8 Ω
Power setting ⁴⁾	0 ... 57,600 W	0 ... 57,600 W	0 ... 37,800 W	0 ... 25,200 W	0 ... 25,200 W
Rise/fall time ⁵⁾	35 μs	30 μs	30 μs	25 μs	30 μs
Input capacity ca.	58 μF	58 μF	52 μF	52 μF	52 μF
Load terminals ⁶⁾ rear / front	FKS40/12-SM12 / -	FKS40/12-SM12 with safety cover / -	FKS40/12-SM12 with safety cover / -	FKS25/10-SM10 with safety cover / -	FKS25/10-SM10 with safety cover / -
Mains voltage ⁷⁾	1/N/PE AC 230 V 50 ... 60 Hz	1/N/PE AC 230 V 50 ... 60 Hz	1/N/PE AC 230 V 50 ... 60 Hz	1/N/PE AC 230 V 50 ... 60 Hz	1/N/PE AC 230 V 50 ... 60 Hz
Mains voltage toggleable ⁷⁾	1/N/PE AC 115 V 50 ... 60 Hz	1/N/PE AC 115 V 50 ... 60 Hz	1/N/PE AC 115 V 50 ... 60 Hz	1/N/PE AC 115 V 50 ... 60 Hz	1/N/PE AC 115 V 50 ... 60 Hz
Power consumption	1,050 VA	1,050 VA	1,050 VA	1,050 VA	1,050 VA
Noise max. ⁸⁾	80 dB(A)	80 dB(A)	80 dB(A)	80 dB(A)	80 dB(A)
Weight ca.	160 kg	160 kg	160 kg	155 kg	160 kg
Housing / 3D model ⁹⁾	19", 20 U / PLI_M40	19", 20 U / PLI_M40	19", 20 U / PLI_M40	19", 20 U / PLI_M39	19", 20 U / PLI_M39

Model (Order number)	PLI606ZV	PLI612ZV	PLI1206ZV	PLI2606ZV	PLI2306ZV
Maximum input voltage V _{max}	60 V	120 V	60 V	60 V	60 V
Minimum input voltage V _{min} ¹⁾	10 mV	10 mV	10 mV	10 mV	10 mV
Maximum current I _{max} ²⁾	60 A	20 A	120 A	200 A	300 A
Continuous power	600 W	600 W	1,200 W	2,600 W	2,300 W
Short-time power ³⁾	1,000 W	1,200 W	2,400 W	5,800 W	5,500 W
Voltage setting	0 ... 60 V	0 ... 60 V	0 ... 60 V	0 ... 60 V	0 ... 60 V
Current setting	0 ... 60 A	0 ... 20 A	0 ... 120 A	0 ... 200 A	0 ... 300 A
Resistance setting	34 mΩ ... 10.75 Ω	100 mΩ ... 64 Ω	17 mΩ ... 5.37 Ω	10 mΩ ... 3.22 Ω	7 mΩ ... 2.15 Ω
Power setting ⁴⁾	0 ... 1,000 W	0 ... 1,200 W	0 ... 2,400 W	0 ... 5,800 W	0 ... 5,500 W
Rise/fall time ⁵⁾	30 μs	40 μs	30 μs	20 μs	20 μs
Input capacity ca.	2 μF	2 μF	4 μF	6 μF	6 μF
Load terminals ⁶⁾ rear / front	FKS20/5-SM8 / BPK4-60L	FKS20/5-SM8 / -	FKS20/5-SM8 / -	FKS25/10-SM10 / -	FKS25/10-SM10 / -
Mains voltage ⁷⁾	1/N/PE AC 230 V 50 ... 60 Hz	1/N/PE AC 230 V 50 ... 60 Hz	1/N/PE AC 230 V 50 ... 60 Hz	1/N/PE AC 230 V 50 ... 60 Hz	1/N/PE AC 230 V 50 ... 60 Hz
Mains voltage toggleable ⁷⁾	1/N/PE AC 115 V 50 ... 60 Hz	-	1/N/PE AC 115 V 50 ... 60 Hz	-	-
Power consumption	300 VA	178 VA	600 VA	960 VA	1,300 VA
Noise max. ⁸⁾	58 dB(A)	55 dB(A)	62 dB(A)	71 dB(A)	71 dB(A)
Weight ca.	9 kg	13 kg	16.5 kg	47 kg	52 kg
Housing / 3D model ⁹⁾	19", 2 U / PLI_M6	19", 2 U / PLI_M6	19", 2 U / PLI_M6	19", 8 U / PLI_M23	19", 8 U / PLI_M23

1. Minimum voltage for maximum load current, linear derating to 0 V.
2. Each current range of a higher voltage class in the same power class can be chosen as special current range.
3. Level and duration of short-time power see diagram in technical data at page 53.
4. The setting range reaches up to the short-time power.
5. Rise and fall times are defined from 10 ... 90 % and 90 ... 10 % of maximum current at "fast" regulation speed (constant current mode, Tolerance ±20 %). Rise and fall time in „medium“ regulation speed: ca. 150 μs, „slow“: ca. 2 ms.
6. Description of available terminals starting at page 109.
7. Mains voltage tolerance: ±10 %
8. Measured at the front in distance of 1 m.
9. 1 U = 44.45 mm. Detailed dimensions by means of 3D models at www.hoecherl-hackl.com/downloads.

Model (Order number)	PLI2106ZV	PLI3706ZV	PLI3506ZV	PLI3206ZV	PLI4806ZV
Maximum input voltage V_{max}	60 V	60 V	60 V	60 V	60 V
Minimum input voltage V_{min} ¹⁾	10 mV	10 mV	10 mV	10 mV	10 mV
Maximum current I_{max} ²⁾	360 A	360 A	450 A	540 A	540 A
Continuous power	2,100 W	3,700 W	3,500 W	3,200 W	4,800 W
Short-time power ³⁾	5,300 W	8,500 W	8,200 W	8,000 W	11,000 W
Voltage setting	0 ... 60 V	0 ... 60 V	0 ... 60 V	0 ... 60 V	0 ... 60 V
Current setting	0 ... 360 A	0 ... 360 A	0 ... 450 A	0 ... 540 A	0 ... 540 A
Resistance setting	6 mΩ ... 1.79 Ω	6 mΩ ... 1.79 Ω	5 mΩ ... 1.43 Ω	4 mΩ ... 1.19 Ω	4 mΩ ... 1.19 Ω
Power setting ⁴⁾	0 ... 5,300 W	0 ... 8,500 W	0 ... 8,200 W	0 ... 8,000 W	0 ... 11,000 W
Rise/fall time ⁵⁾	20 μs	25 μs	20 μs	20 μs	20 μs
Input capacity ca.	8 μF	8 μF	8 μF	8 μF	8 μF
Load terminals ⁶⁾ rear / front	FKS25/10-SM10 / -	FKS25/10-SM10 / -	FKS25/10-SM10 / -	FKS25/10-SM10 / -	FKS25/10-SM10 / -
Mains voltage ⁷⁾	1/N/PE AC 230 V 50 ... 60 Hz	1/N/PE AC 230 V 50 ... 60 Hz	1/N/PE AC 230 V 50 ... 60 Hz	1/N/PE AC 230 V 50 ... 60 Hz	1/N/PE AC 230 V 50 ... 60 Hz
Mains voltage toggleable ⁷⁾	-	-	-	-	-
Power consumption	1,500 VA	1,770 VA	2,100 VA	2,500 VA	2,500 VA
Noise max. ⁸⁾	71 dB(A)	77 dB(A)	77 dB(A)	77 dB(A)	79 dB(A)
Weight ca.	52 kg	53.5 kg	56 kg	56 kg	73 kg
Housing / 3D model ⁹⁾	19", 8 U / PLI_M23	19", 8 U / PLI_M23	19", 8 U / PLI_M23	19", 8 U / PLI_M23	19", 11 U / PLI_M27

Model (Order number)	PLI4606ZV	PLI4306ZV	PLI6006ZV	PLI7506ZV
Maximum input voltage V_{max}	60 V	60 V	60 V	60 V
Minimum input voltage V_{min} ¹⁾	10 mV	10 mV	10 mV	10 mV
Maximum current I_{max} ²⁾	600 A	720 A	720 A	720 A
Continuous power	4,600 W	4,300 W	6,000 W	7,500 W
Short-time power ³⁾	11,000 W	10,500 W	14,000 W	17,000 W
Voltage setting	0 ... 60 V	0 ... 60 V	0 ... 60 V	0 ... 60 V
Current setting	0 ... 600 A	0 ... 720 A	0 ... 720 A	0 ... 720 A
Resistance setting	4 mΩ ... 1.07 Ω	3 mΩ ... 0.89 Ω	3 mΩ ... 0.89 Ω	3 mΩ ... 0.89 Ω
Power setting ⁴⁾	0 ... 11,000 W	0 ... 10,500 W	0 ... 14,000 W	0 ... 17,000 W
Rise/fall time ⁵⁾	20 μs	20 μs	20 μs	20 μs
Input capacity ca.	10 μF	10 μF	12 μF	14 μF
Load terminals ⁶⁾ rear / front	FKS25/10-SM10 / -	FKS25/10-SM10 / -	FKS25/10-SM10 / -	FKS25/10-SM10 / -
Mains voltage ⁷⁾	3/N/PE AC 400/230 V 50 ... 60 Hz, 16 A	3/N/PE AC 400/230 V 50 ... 60 Hz, 16 A	3/N/PE AC 400/230 V 50 ... 60 Hz, 16 A	3/N/PE AC 400/230 V 50 ... 60 Hz, 16 A
Mains voltage toggleable ⁷⁾	-	-	-	-
Power consumption	2,800 VA	3,300 VA	3,300 VA	3,300 VA
Noise max. ⁸⁾	79 dB(A)	79 dB(A)	80 dB(A)	80 dB(A)
Weight ca.	75.5 kg	75.5 kg	76.5 kg	82.5 kg
Housing / 3D model ⁹⁾	19", 11 U / PLI_M27	19", 11 U / PLI_M27	19", 11 U / PLI_M27	19", 11 U / PLI_M27

1. Minimum voltage for maximum load current, linear derating to 0 V.
2. Each current range of a higher voltage class in the same power class can be chosen as special current range.
3. Level and duration of short-time power see diagram in technical data at page 53.
4. The setting range reaches up to the short-time power.
5. Rise and fall times are defined from 10 ... 90 % and 90 ... 10 % of maximum current at "fast" regulation speed (constant current mode, Tolerance ±20 %). Rise and fall time in „medium“ regulation speed: ca. 150 μs, „slow“: ca. 2 ms.
6. Description of available terminals starting at page 109.
7. Mains voltage tolerance: ±10 %
8. Measured at the front in distance of 1 m.
9. 1 U = 44.45 mm. Detailed dimensions by means of 3D models at www.hoerchl-hackl.com/downloads.

Model (Order number)	PLI24K12HV	PLI36K12HV	PLI48K12HV	PLI60K12HV	PLI72K12HV
Maximum input voltage V _{max}	1,200 V	1,200 V	1,200 V	1,200 V	1,200 V
Minimum input voltage V _{min} ¹⁾	1.6 V	2 V	2 V	1.5 V	2 V
Maximum current I _{max} ²⁾	12 A	18 A	24 A	30 A	36 A
Continuous power	2,400 W	3,600 W	4,800 W	6,000 W	7,200 W
Short-time power ³⁾	2,400 W	3,600 W	4,800 W	6,000 W	7,200 W
Voltage setting	0 ... 1,200 V	0 ... 1,200 V	0 ... 1,200 V	0 ... 1,200 V	0 ... 1,200 V
Current setting	0 ... 12 A	0 ... 18 A	0 ... 24 A	0 ... 30 A	0 ... 36 A
Resistance setting	167 mΩ ... 1075 Ω	112 mΩ ... 716 Ω	84 mΩ ... 537 Ω	67 mΩ ... 430 Ω	56 mΩ ... 358 Ω
Power setting ⁴⁾	0 ... 2,400 W	0 ... 3,600 W	0 ... 4,800 W	0 ... 6,000 W	0 ... 7,200 W
Rise/fall time ⁵⁾	30 μs	20 μs	20 μs	25 μs	20 μs
Input capacity ca.	6 μF	8 μF	10 μF	12 μF	14 μF
Load terminals ⁶⁾ rear / front	SBU4-32 / -	FKS25/10-SM10 with safety cover / -	FKS25/10-SM10 with safety cover / -	FKS25/10-SM10 with safety cover / -	FKS25/10-SM10 with safety cover / -
Mains voltage ⁷⁾	1/N/PE AC 230 V 50 ... 60 Hz	1/N/PE AC 230 V 50 ... 60 Hz	1/N/PE AC 230 V 50 ... 60 Hz	1/N/PE AC 230 V 50 ... 60 Hz	1/N/PE AC 230 V 50 ... 60 Hz
Mains voltage toggleable ⁷⁾	1/N/PE AC 115 V 50 ... 60 Hz	1/N/PE AC 115 V 50 ... 60 Hz	1/N/PE AC 115 V 50 ... 60 Hz	1/N/PE AC 115 V 50 ... 60 Hz	1/N/PE AC 115 V 50 ... 60 Hz
Power consumption	140 VA	190 VA	275 VA	320 VA	380 VA
Noise max. ⁸⁾	70 dB(A)	71 dB(A)	73 dB(A)	74 dB(A)	74 dB(A)
Weight ca.	20 kg	39 kg	56 kg	56 kg	63 kg
Housing / 3D model ⁹⁾	19", 3 U /	19", 5 U / PLI_M19	19", 8 U / PLI_M23	19", 8 U / PLI_M23	19", 8 U / PLI_M23

Model (Order number)	PLI84K12HV	PLI96K12HV	PLI108K12HV	PLI120K12HV	PLI132K12HV	PLI144K12HV
Maximum input voltage V _{max}	1,200 V	1,200 V	1,200 V	1,200 V	1,200 V	1,200 V
Minimum input voltage V _{min} ¹⁾	2 V	2 V	2 V	2 V	2 V	2 V
Maximum current I _{max} ²⁾	42 A	48 A	54 A	60 A	66 A	72 A
Continuous power	8,400 W	9,600 W	10,800 W	12,000 W	13,200 W	14,400 W
Short-time power ³⁾	8,400 W	9,600 W	10,800 W	12,000 W	13,200 W	14,400 W
Voltage setting	0 ... 1,200 V	0 ... 1,200 V	0 ... 1,200 V	0 ... 1,200 V	0 ... 1,200 V	0 ... 1,200 V
Current setting	0 ... 42 A	0 ... 48 A	0 ... 54 A	0 ... 60 A	0 ... 66 A	0 ... 72 A
Resistance setting	48 mΩ ... 307 Ω	42 mΩ ... 268 Ω	38 mΩ ... 238 Ω	34 mΩ ... 215 Ω	31 mΩ ... 195 Ω	28 mΩ ... 179 Ω
Power setting ⁴⁾	0 ... 8,400 W	0 ... 9,600 W	0 ... 10,800 W	0 ... 12,000 W	0 ... 13,200 W	0 ... 14,400 W
Rise/fall time ⁵⁾	25 μs	25 μs	25 μs	25 μs	25 μs	25 μs
Input capacity ca.	18 μF	20 μF	22 μF	24 μF	28 μF	30 μF
Load terminals ⁶⁾ rear / front	FKS25/10-SM10 with safety cover / -	FKS25/10-SM10 with safety cover / -	FKS25/10-SM10 with safety cover / -	FKS25/10-SM10 with safety cover / -	FKS25/10-SM10 with safety cover / -	FKS25/10-SM10 with safety cover / -
Mains voltage ⁷⁾	1/N/PE AC 230 V 50 ... 60 Hz	1/N/PE AC 230 V 50 ... 60 Hz	1/N/PE AC 230 V 50 ... 60 Hz	1/N/PE AC 230 V 50 ... 60 Hz	1/N/PE AC 230 V 50 ... 60 Hz	1/N/PE AC 230 V 50 ... 60 Hz
Mains voltage toggleable ⁷⁾	1/N/PE AC 115 V 50 ... 60 Hz	1/N/PE AC 115 V 50 ... 60 Hz	1/N/PE AC 115 V 50 ... 60 Hz	1/N/PE AC 115 V 50 ... 60 Hz	1/N/PE AC 115 V 50 ... 60 Hz	1/N/PE AC 115 V 50 ... 60 Hz
Power consumption	450 VA	500 VA	540 VA	600 VA	675 VA	700 VA
Noise max. ⁸⁾	75 dB(A)	76 dB(A)	76 dB(A)	77 dB(A)	77 dB(A)	77 dB(A)
Weight ca.	74 kg	82 kg	85 kg	104 kg	98 kg	112 kg
Housing / 3D model ⁹⁾	19", 11 U / PLI_M27	19", 11 U / PLI_M27	19", 11 U / PLI_M27	19", 14 U / PLI_M31	19", 14 U / PLI_M31	19", 14 U / PLI_M31

1. Minimum voltage for maximum load current, linear derating to 0 V.
 2. Each current range of a higher voltage class in the same power class can be chosen as special current range.
 3. Level and duration of short-time power see diagram in technical data at page 53.
 4. The setting range reaches up to the short-time power.
 5. Rise and fall times are defined from 10 ... 90 % and 90 ... 10 % of maximum current at "fast" regulation speed (constant current mode, Tolerance ±20 %). Rise and fall time in „medium“ regulation speed: ca. 150 μs, „slow“: ca. 2 ms.
 6. Description of available terminals starting at page 109.
 7. Mains voltage tolerance: ±10 %
 8. Measured at the front in distance of 1 m.
 9. 1 U = 44.45 mm. Detailed dimensions by means of 3D models at www.hoecherl-hackl.com/downloads.

Model (Order number)	PLI3230EC	PLI4230EC	PLI5630EC	PLI7030EC	PLI8430EC	PLI9830EC
Maximum input voltage V _{max}	300 V	300 V	300 V	300 V	300 V	300 V
Minimum input voltage V _{min} ¹⁾	6 V	5 V	5 V	5 V	5 V	5 V
Maximum current I _{max} ²⁾	208 A	312 A	416 A	520 A	624 A	728 A
Continuous power	3,200 W	4,200 W	5,600 W	7,000 W	8,400 W	9,800 W
Short-time power ³⁾	3,200 W	4,200 W	5,600 W	7,000 W	8,400 W	9,800 W
Voltage setting	0 ... 300 V	0 ... 300 V	0 ... 300 V	0 ... 300 V	0 ... 300 V	0 ... 300 V
Current setting	0 ... 208 A	0 ... 312 A	0 ... 416 A	0 ... 520 A	0 ... 624 A	0 ... 728 A
Resistance setting	25 mΩ ... 15.5 Ω	17 mΩ ... 10.3 Ω	13 mΩ ... 7.75 Ω	10 mΩ ... 6.2 Ω	9 mΩ ... 5.16 Ω	7 mΩ ... 4.3 Ω
Power setting ⁴⁾	0 ... 3,200 W	0 ... 4,200 W	0 ... 5,600 W	0 ... 7,000 W	0 ... 8,400 W	0 ... 9,800 W
Rise/fall time ⁵⁾	30 μs	30 μs	30 μs	30 μs	30 μs	30 μs
Input capacity ca.	8 μF	10 μF	12 μF	14 μF	18 μF	20 μF
Load terminals ⁶⁾ rear / front	FKS25/8-SM10 with safety cover / -	FKS25/10-SM10 with safety cover / -	FKS25/10-SM10 with safety cover / -	FKS40/12-SM12 with safety cover / -	FKS40/12-SM12 with safety cover / -	FKS40/12-SM12 with safety cover / -
Mains voltage ⁷⁾	1/N/PE AC 230 V 50 ... 60 Hz	1/N/PE AC 230 V 50 ... 60 Hz	1/N/PE AC 230 V 50 ... 60 Hz	1/N/PE AC 230 V 50 ... 60 Hz	1/N/PE AC 230 V 50 ... 60 Hz	1/N/PE AC 230 V 50 ... 60 Hz
Mains voltage toggleable ⁷⁾	1/N/PE AC 115 V 50 ... 60 Hz	1/N/PE AC 115 V 50 ... 60 Hz	1/N/PE AC 115 V 50 ... 60 Hz	1/N/PE AC 115 V 50 ... 60 Hz	1/N/PE AC 115 V 50 ... 60 Hz	1/N/PE AC 115 V 50 ... 60 Hz
Power consumption	140 VA	190 VA	275 VA	320 VA	380 VA	450 VA
Noise max. ⁸⁾	70 dB(A)	71 dB(A)	73 dB(A)	74 dB(A)	74 dB(A)	75 dB(A)
Weight ca.	22.5 kg	39 kg	56 kg	59 kg	63 kg	80 kg
Housing / 3D model ⁹⁾	19", 3 U / PLI_M12	19", 5 U / PLI_M19	19", 8 U / PLI_M23	19", 8 U / PLI_M24	19", 8 U / PLI_M24	19", 8 U / PLI_M28

Model (Order number)	PLI11230EC	PLI12630EC	PLI14030EC	PLI15430EC	PLI16830EC	PLI18230EC
Maximum input voltage V _{max}	300 V	300 V	300 V	300 V	300 V	300 V
Minimum input voltage V _{min} ¹⁾	5 V	5 V	5 V	5 V	5 V	5 V
Maximum current I _{max} ²⁾	832 A	936 A	1,040 A	1,144 A	1,248 A	1,352 A
Continuous power	11,200 W	12,600 W	14,000 W	15,400 W	16,800 W	18,200 W
Short-time power ³⁾	11,200 W	12,600 W	14,000 W	15,400 W	16,800 W	18,200 W
Voltage setting	0 ... 300 V	0 ... 300 V	0 ... 300 V	0 ... 300 V	0 ... 300 V	0 ... 300 V
Current setting	0 ... 832 A	0 ... 936 A	0 ... 1,040 A	0 ... 1,144 A	0 ... 1,248 A	0 ... 1,352 A
Resistance setting	7 mΩ ... 3.87 Ω	6 mΩ ... 3.44 Ω	5 mΩ ... 3.10 Ω	5 mΩ ... 2.81 Ω	5 mΩ ... 2.58 Ω	4 mΩ ... 2.38 Ω
Power setting ⁴⁾	0 ... 11,200 W	0 ... 12,600 W	0 ... 14,000 W	0 ... 15,400 W	0 ... 16,800 W	0 ... 18,200 W
Rise/fall time ⁵⁾	30 μs	30 μs	30 μs	30 μs	30 μs	30 μs
Input capacity ca.	24 μF	26 μF	28 μF	32 μF	34 μF	38 μF
Load terminals ⁶⁾ rear / front	FKS40/12-SM12 with safety cover	FKS40/12-SM12 with safety cover	FKS40/12-SM12 with safety cover	FKS40/12-SM12 with safety cover	FKS40/12-SM12 with safety cover	FKS40/12-SM12 with safety cover
Mains voltage ⁷⁾	1/N/PE AC 230 V 50 ... 60 Hz	1/N/PE AC 230 V 50 ... 60 Hz	1/N/PE AC 230 V 50 ... 60 Hz	1/N/PE AC 230 V 50 ... 60 Hz	1/N/PE AC 230 V 50 ... 60 Hz	1/N/PE AC 230 V 50 ... 60 Hz
Mains voltage toggleable ⁷⁾	1/N/PE AC 115 V 50 ... 60 Hz	1/N/PE AC 115 V 50 ... 60 Hz	1/N/PE AC 115 V 50 ... 60 Hz	1/N/PE AC 115 V 50 ... 60 Hz	1/N/PE AC 115 V 50 ... 60 Hz	1/N/PE AC 115 V 50 ... 60 Hz
Power consumption	500 VA	540 VA	600 VA	675 VA	700 VA	770 VA
Noise max. ⁸⁾	76 dB(A)	76 dB(A)	77 dB(A)	77 dB(A)	77 dB(A)	77 dB(A)
Weight ca.	82 kg	87 kg	104 kg	105 kg	112 kg	126 kg
Housing / 3D model ⁹⁾	19", 11 U / PLI_M28	19", 11 U / PLI_M28	19", 14 U / PLI_M32	19", 14 U / PLI_M32	19", 14 U / PLI_M32	19", 17 U / PLI_M36

1. Minimum voltage for maximum load current, linear derating to 0 V.
2. Each current range of a higher voltage class in the same power class can be chosen as special current range.
3. Level and duration of short-time power see diagram in technical data at page 53.
4. The setting range reaches up to the short-time power.
5. Rise and fall times are defined from 10 ... 90 % and 90 ... 10 % of maximum current at "fast" regulation speed (constant current mode, Tolerance ±20 %). Rise and fall time in „medium“ regulation speed: ca. 150 μs, „slow“: ca. 2 ms.
6. Description of available terminals starting at page 109.
7. Mains voltage tolerance: ±10 %
8. Measured at the front in distance of 1 m.
9. 1 U = 44.45 mm. Detailed dimensions by means of 3D models at www.hoecherl-hackl.com/downloads.

Model (Order number)	PLI19630EC	PLI21030EC	PLI22430EC	PLI23830EC	PLI25230EC
Maximum input voltage V _{max}	300 V	300 V	300 V	300 V	300 V
Minimum input voltage V _{min} ¹⁾	5 V	5 V	5 V	5 V	5 V
Maximum current I _{max} ²⁾	1,456 A	1,560 A	1,664 A	1,768 A	1,872 A
Continuous power	19,600 W	21,000 W	22,400 W	23,800 W	25,200 W
Short-time power ³⁾	19,600 W	21,000 W	22,400 W	23,800 W	25,200 W
Voltage setting	0 ... 300 V	0 ... 300 V	0 ... 300 V	0 ... 300 V	0 ... 300 V
Current setting	0 ... 1,456 A	0 ... 1,560 A	0 ... 1,664 A	0 ... 1,768 A	0 ... 1,872 A
Resistance setting	4 mΩ ... 2.21 Ω	4 mΩ ... 2.0 Ω	3 mΩ ... 1.93 Ω	3 mΩ ... 1.82 Ω	3 mΩ ... 1.72 Ω
Power setting ⁴⁾	0 ... 19,600 W	0 ... 21,000 W	0 ... 22,400 W	0 ... 23,800 W	0 ... 25,200 W
Rise/fall time ⁵⁾	30 μs	30 μs	30 μs	30 μs	30 μs
Input capacity ca.	40 μF	44 μF	46 μF	48 μF	52 μF
Load terminals ⁶⁾ rear / front	FKS40/12-SM12 with safety cover / -	FKS40/12-SM12 with safety cover / -	FKS40/12-SM12 with safety cover / -	FKS40/12-SM12 with safety cover / -	FKS40/12-SM12 with safety cover / -
Mains voltage ⁷⁾	1/N/PE AC 230 V 50 ... 60 Hz	1/N/PE AC 230 V 50 ... 60 Hz	1/N/PE AC 230 V 50 ... 60 Hz	1/N/PE AC 230 V 50 ... 60 Hz	1/N/PE AC 230 V 50 ... 60 Hz
Mains voltage toggleable ⁷⁾	1/N/PE AC 115 V 50 ... 60 Hz	1/N/PE AC 115 V 50 ... 60 Hz	1/N/PE AC 115 V 50 ... 60 Hz	1/N/PE AC 115 V 50 ... 60 Hz	1/N/PE AC 115 V 50 ... 60 Hz
Power consumption	810 VA	875 VA	900 VA	1000 VA	1050 VA
Noise max. ⁸⁾	78 dB(A)	78 dB(A)	80 dB(A)	80 dB(A)	80 dB(A)
Weight ca.	131 kg	136 kg	142 kg	152 kg	160 kg
Housing / 3D model ⁹⁾	19", 17 U / PLI_M36	19", 17 U / PLI_M36	19", 20 U / PLI_M40	19", 20 U / PLI_M40	19", 20 U / PLI_M40

Model (Order number)	PLI3260EC	PLI4260EC	PLI5660EC	PLI7060EC	PLI8460EC	PLI9860EC
Maximum input voltage V _{max}	600 V	600 V	600 V	600 V	600 V	600 V
Minimum input voltage V _{min} ¹⁾	5 V	5 V	5 V	5 V	5 V	5 V
Maximum current I _{max} ²⁾	104 A	156 A	208 A	260 A	312 A	364 A
Continuous power	3,200 W	4,200 W	5,600 W	7,000 W	8,400 W	9,800 W
Short-time power ³⁾	3,200 W	4,200 W	5,600 W	7,000 W	8,400 W	9,800 W
Voltage setting	0 ... 600 V	0 ... 600 V	0 ... 600 V	0 ... 600 V	0 ... 600 V	0 ... 600 V
Current setting	0 ... 104 A	0 ... 156 A	0 ... 208 A	0 ... 260 A	0 ... 312 A	0 ... 364 A
Resistance setting	49 mΩ ... 62.0 Ω	33 mΩ ... 41.3 Ω	25 mΩ ... 31 Ω	20 mΩ ... 24.8 Ω	17 mΩ ... 20.6 Ω	14 mΩ ... 17.7 Ω
Power setting ⁴⁾	0 ... 3,200 W	0 ... 4,200 W	0 ... 5,600 W	0 ... 7,000 W	0 ... 8,400 W	0 ... 9,800 W
Rise/fall time ⁵⁾	30 μs	30 μs	30 μs	30 μs	30 μs	30 μs
Input capacity ca.	8 μF	10 μF	12 μF	14 μF	18 μF	20 μF
Load terminals ⁶⁾ rear / front	FKS25/8-SM10 with safety cover / -	FKS25/10-SM10 with safety cover / -	FKS25/10-SM10 with safety cover / -	FKS25/10-SM10 with safety cover / -	FKS25/10-SM10 with safety cover / -	FKS25/10-SM10 with safety cover / -
Mains voltage ⁷⁾	1/N/PE AC 230 V 50 ... 60 Hz	1/N/PE AC 230 V 50 ... 60 Hz	1/N/PE AC 230 V 50 ... 60 Hz	1/N/PE AC 230 V 50 ... 60 Hz	1/N/PE AC 230 V 50 ... 60 Hz	1/N/PE AC 230 V 50 ... 60 Hz
Mains voltage toggleable ⁷⁾	1/N/PE AC 115 V 50 ... 60 Hz	1/N/PE AC 115 V 50 ... 60 Hz	1/N/PE AC 115 V 50 ... 60 Hz	1/N/PE AC 115 V 50 ... 60 Hz	1/N/PE AC 115 V 50 ... 60 Hz	1/N/PE AC 115 V 50 ... 60 Hz
Power consumption	140 VA	190 VA	275 VA	320 VA	380 VA	450 VA
Noise max. ⁸⁾	70 dB(A)	71 dB(A)	73 dB(A)	74 dB(A)	74 dB(A)	75 dB(A)
Weight ca.	20.5 kg	38 kg	56 kg	57 kg	63 kg	74 kg
Housing / 3D model ⁹⁾	19", 3 U / PLI_M12	19", 5 U / PLI_M19	19", 8 U / PLI_M23	19", 8 U / PLI_M23	19", 8 U / PLI_M23	19", 11 U / PLI_M27

1. Minimum voltage for maximum load current, linear derating to 0 V.
2. Each current range of a higher voltage class in the same power class can be chosen as special current range.
3. Level and duration of short-time power see diagram in technical data at page 53.
4. The setting range reaches up to the short-time power.
5. Rise and fall times are defined from 10 ... 90 % and 90 ... 10 % of maximum current at "fast" regulation speed (constant current mode, Tolerance ±20 %). Rise and fall time in „medium“ regulation speed: ca. 150 μs, „slow“: ca. 2 ms.
6. Description of available terminals starting at page 109.
7. Mains voltage tolerance: ±10 %
8. Measured at the front in distance of 1 m.
9. 1 U = 44.45 mm. Detailed dimensions by means of 3D models at www.hoercherl-hackl.com/downloads.

Model (Order number)	PLI11260EC	PLI12660EC	PLI14060EC	PLI15460EC	PLI16860EC	PLI18260EC
Maximum input voltage V _{max}	600 V	600 V	600 V	600 V	600 V	600 V
Minimum input voltage V _{min} ¹⁾	5 V	5 V	5 V	5 V	5 V	5 V
Maximum current I _{max} ²⁾	416 A	468 A	520 A	572 A	624 A	676 A
Continuous power	11,200 W	12,600 W	14,000 W	15,400 W	16,800 W	18,200 W
Short-time power ³⁾	11,200 W	12,600 W	14,000 W	15,400 W	16,800 W	18,200 W
Voltage setting	0 ... 600 V	0 ... 600 V	0 ... 600 V	0 ... 600 V	0 ... 600 V	0 ... 600 V
Current setting	0 ... 416 A	0 ... 468 A	0 ... 520 A	0 ... 572 A	0 ... 624 A	0 ... 676 A
Resistance setting	13 mΩ ... 15. Ω	11 mΩ ... 13.7 Ω	10 mΩ ... 12.4 Ω	9 mΩ ... 11.2 Ω	8 mΩ ... 10.3 Ω	8 mΩ ... 9.5 Ω
Power setting ⁴⁾	0 ... 11,200 W	0 ... 12,600 W	0 ... 14,000 W	0 ... 15,400 W	0 ... 16,800 W	0 ... 18,200 W
Rise/fall time ⁵⁾	30 μs	20 μs	30 μs	30 μs	30 μs	30 μs
Input capacity ca.	24 μF	26 μF	28 μF	32 μF	34 μF	38 μF
Load terminals ⁶⁾ rear / front	FKS25/10-SM10 with safety cover / -	FKS25/10-SM10 with safety cover / -	FKS40/12-SM12 with safety cover / -	FKS40/12-SM12 with safety cover / -	FKS40/12-SM12 with safety cover / -	FKS40/12-SM12 with safety cover / -
Mains voltage ⁷⁾	1/N/PE AC 230 V 50 ... 60 Hz	1/N/PE AC 230 V 50 ... 60 Hz	1/N/PE AC 230 V 50 ... 60 Hz	1/N/PE AC 230 V 50 ... 60 Hz	1/N/PE AC 230 V 50 ... 60 Hz	1/N/PE AC 230 V 50 ... 60 Hz
Mains voltage toggleable ⁷⁾	1/N/PE AC 115 V 50 ... 60 Hz	1/N/PE AC 115 V 50 ... 60 Hz	1/N/PE AC 115 V 50 ... 60 Hz	1/N/PE AC 115 V 50 ... 60 Hz	1/N/PE AC 115 V 50 ... 60 Hz	1/N/PE AC 115 V 50 ... 60 Hz
Power consumption	500 VA	540 VA	600 VA	675 VA	700 VA	770 VA
Noise max. ⁸⁾	76 dB(A)	76 dB(A)	77 dB(A)	77 dB(A)	77 dB(A)	77 dB(A)
Weight ca.	82 kg	89 kg	104 kg	105 kg	112 kg	126 kg
Housing / 3D model ⁹⁾	19", 11 U / PLI_M27	19", 11 U / PLI_M27	19", 14 U / PLI_M32	19", 14 U / PLI_M32	19", 14 U / PLI_M32	19", 17 U / PLI_M36

Model (Order number)	PLI19660EC	PLI21060EC	PLI22460EC	PLI23860EC	PLI25260EC
Maximum input voltage V _{max}	600 V	600 V	600 V	600 V	600 V
Minimum input voltage V _{min} ¹⁾	2.5 V	5 V	5 V	5 V	5 V
Maximum current I _{max} ²⁾	728 A	780 A	832 A	884 A	936 A
Continuous power	19,600 W	21,000 W	22,400 W	23,800 W	25,200 W
Short-time power ³⁾	19,600 W	21,000 W	22,400 W	23,800 W	25,200 W
Voltage setting	0 ... 600 V	0 ... 600 V	0 ... 600 V	0 ... 600 V	0 ... 600 V
Current setting	0 ... 728 A	0 ... 780 A	0 ... 832 A	0 ... 884 A	0 ... 936 A
Resistance setting	7 mΩ ... 8.86 Ω	7 mΩ ... 8.27 Ω	6 mΩ ... 7.75 Ω	6 mΩ ... 7.29 Ω	6 mΩ ... 6.89 Ω
Power setting ⁴⁾	0 ... 19,600 W	0 ... 21,000 W	0 ... 22,400 W	0 ... 23,800 W	0 ... 25,200 W
Rise/fall time ⁵⁾	30 μs	40 μs	40 μs	50 μs	50 μs
Input capacity ca.	40 μF	42 μF	46 μF	48 μF	52 μF
Load terminals ⁶⁾ rear / front	FKS40/12-SM12 with safety cover / -	FKS40/12-SM12 with safety cover / -	FKS40/12-SM12 with safety cover / -	FKS40/12-SM12 with safety cover / -	FKS40/12-SM12 with safety cover / -
Mains voltage ⁷⁾	1/N/PE AC 230 V 50 ... 60 Hz	1/N/PE AC 230 V 50 ... 60 Hz	1/N/PE AC 230 V 50 ... 60 Hz	1/N/PE AC 230 V 50 ... 60 Hz	1/N/PE AC 230 V 50 ... 60 Hz
Mains voltage toggleable ⁷⁾	1/N/PE AC 115 V 50 ... 60 Hz	1/N/PE AC 115 V 50 ... 60 Hz	1/N/PE AC 115 V 50 ... 60 Hz	1/N/PE AC 115 V 50 ... 60 Hz	1/N/PE AC 115 V 50 ... 60 Hz
Power consumption	810 VA	875 VA	900 VA	1000 VA	1050 VA
Noise max. ⁸⁾	78 dB(A)	78 dB(A)	80 dB(A)	80 dB(A)	80 dB(A)
Weight ca.	131 kg	136 kg	142 kg	152 kg	155 kg
Housing / 3D model ⁹⁾	19", 17 U / PLI_M36	19", 17 U / PLI_M36	19", 20 U / PLI_M40	19", 20 U / PLI_M40	19", 20 U / PLI_M40

1. Minimum voltage for maximum load current, linear derating to 0 V.
2. Each current range of a higher voltage class in the same power class can be chosen as special current range.
3. Level and duration of short-time power see diagram in technical data at page 53.
4. The setting range reaches up to the short-time power.
5. Rise and fall times are defined from 10 ... 90 % and 90 ... 10 % of maximum current at "fast" regulation speed (constant current mode, Tolerance ±20 %). Rise and fall time in „medium“ regulation speed: ca. 150 μs, „slow“: ca. 2 ms.
6. Description of available terminals starting at page 109.
7. Mains voltage tolerance: ±10 %
8. Measured at the front in distance of 1 m.
9. 1 U = 44.45 mm. Detailed dimensions by means of 3D models at www.hoechert-hackl.com/downloads.

Model (Order number)		PLI508MR4	PLI512MR4	PLI530MR3	PLI580MR3	PLI1008MR4	PLI1012MR4
Maximum input voltage Vmax		80 V	120 V	300 V	800 V	80 V	120 V
Minimum input voltage Vmin ¹⁾	R1	0.8 V	0.8 V	0.8 V	1.2 V	0.8 V	0.8 V
	R2	0.8 V	0.8 V	0.8 V	1.2 V	0.8 V	0.8 V
	R3	0.8 V	0.8 V	1.5 V	2.4 V	0.8 V	0.8 V
	R4	1.5 V	1.5 V	-	-	1.5 V	1.5 V
Voltage range		0 ... 80 V	0 ... 120 V	0 ... 300 V	0 ... 800 V	0 ... 80 V	0 ... 120 V
Maximum current Imax		60 A	40 A	16 A	6 A	120 A	80 A
Current ranges	R1	0 ... 0.06 A	0 ... 0.04 A	0 ... 0.16 A	0 ... 0.06 A	0 ... 0.12 A	0 ... 0.08 A
	R2	0 ... 0.6 A	0 ... 0.4 A	0 ... 1.6 A	0 ... 0.6 A	0 ... 1.2 A	0 ... 0.8 A
	R3	0 ... 6 A	0 ... 4 A	0 ... 16 A	0 ... 6 A	0 ... 12 A	0 ... 8 A
	R4	0 ... 60 A	0 ... 40 A	-	-	0 ... 120 A	0 ... 80 A
Resistance ranges	R1	33.4 Ω ... 14.3 kΩ	50 Ω ... 32.2 kΩ	12.5 Ω ... 20.1 kΩ	33.4 Ω ... 14.3 kΩ	16.6 Ω ... 7.16 kΩ	25 Ω ... 16.1 kΩ
	R2	3.34 Ω ... 1.43 kΩ	5 Ω ... 3.22 kΩ	1.25 Ω ... 2.01 kΩ	3.34 Ω ... 14.3 kΩ	1.66 Ω ... 716 Ω	2.5 Ω ... 1.61 kΩ
	R3	0.34 Ω ... 143 Ω	0.5 Ω ... 322 Ω	0.125 Ω ... 201 Ω	0.34 Ω ... 1.43 kΩ	0.16 Ω ... 71.6 Ω	0.25 Ω ... 161 Ω
	R4	0.034 Ω ... 14.3 Ω	0.05 Ω ... 32.2 Ω	-	-	0.016 Ω ... 7.16 Ω	0.025 Ω ... 16.1 Ω
Power ranges ²⁾ continuous/short-time	R1	0 ... 4.8 W/4.8 W	0 ... 4.8 W/4.8 W	0 ... 48 W/48 W	0 ... 48 W/48 W	0 ... 9.6 W/9.6 W	0 ... 9.6 W/9.6 W
	R2	0 ... 48 W/48 W	0 ... 48 W/48 W	0 ... 300 W/300 W	0 ... 300 W/300 W	0 ... 96 W/96 W	0 ... 96 W/96 W
	R3	0 ... 200 W/200 W	0 ... 200 W/200 W	0 ... 500 W/750 W	0 ... 500 W/500 W	0 ... 400 W/400 W	0 ... 400 W/400 W
	R4	0 ... 500 W/1000 W	0 ... 500 W / 1000 W	-	-	0 ... 1000 W/2000 W	0 ... 1000 W/2000 W
Rise/fall time ³⁾		30 μs	30 μs	30 μs	20 μs	30 μs	30 μs
Input capacity ca.		2 μF	2 μF	2 μF	2 μF	2 μF	2 μF
Load terminals ⁴⁾ rear / front		FKS20/5-SM8 with safety cover / BPK4-60L	BPK4-60L / BPK4-60L	BPK4-30L / BPK4-30L	BPK4-30L / BPK4-30L	FKS20/5-SM8 with safety cover / -	FKS20/5-SM8 with safety cover / -
Mains voltage ⁵⁾		1/N/PE AC 230 V 50 ... 60 Hz	1/N/PE AC 230 V 50 ... 60 Hz	1/N/PE AC 230 V 50 ... 60 Hz	1/N/PE AC 230 V 50 ... 60 Hz	1/N/PE AC 230 V 50 ... 60 Hz	1/N/PE AC 230 V 50 ... 60 Hz
Mains voltage toggleable ⁵⁾		1/N/PE AC 115 V 50 ... 60 Hz	1/N/PE AC 115 V 50 ... 60 Hz	1/N/PE AC 115 V 50 ... 60 Hz	1/N/PE AC 115 V 50 ... 60 Hz	1/N/PE AC 115 V 50 ... 60 Hz	1/N/PE AC 115 V 50 ... 60 Hz
Power consumption		35 VA	35 VA	35 VA	35 VA	55 VA	55 VA
Noise max. ⁴⁾		55 dB(A)	55 dB(A)	55 dB(A)	55 dB(A)	57 dB(A)	57 dB(A)
Weight ca.		9 kg	9 kg	9 kg	9 kg	15 kg	15 kg
Housing / 3D model ⁷⁾		½ 19", 2 U / PLI_M1	½ 19", 2 U / PLI_M3	½ 19", 2 U / PLI_M2	½ 19", 2 U / PLI_M2	19", 2 U / PLI_M6	19", 2 U / PLI_M6

Model (Order number)		PLI1030MR3	PLI1080MR3	PLI1508MR4	PLI1512MR4	PLI1530MR3	PLI1580MR3
Maximum input voltage Vmax		300 V	800 V	80 V	120 V	300 V	800 V
Minimum input voltage Vmin ¹⁾	R1	0.8 V	1.2 V	0.8 V	0.8 V	0.8 V	1.2 V
	R2	0.8 V	1.2 V	0.8 V	0.8 V	0.8 V	1.2 V
	R3	1.5 V	2.4 V	0.8 V	0.8 V	1.5 V	2.4 V
	R4	-	-	1.5 V	1.5 V	-	-
Voltage range		0 ... 300 V	0 ... 800 V	0 ... 80 V	0 ... 120 V	0 ... 300 V	0 ... 800 V
Maximum current Imax		32 A	12 A	180 A	120 A	48 A	18 A
Current ranges	R1	0 ... 0.32 A	0 ... 0.12 A	0 ... 0.18 A	0 ... 0.12 A	0 ... 0.48 A	0 ... 0.18 A
	R2	0 ... 3.2 A	0 ... 1.2 A	0 ... 1.8 A	0 ... 1.2 A	0 ... 4.8 A	0 ... 1.8 A
	R3	0 ... 32 A	0 ... 12 A	0 ... 18 A	0 ... 12 A	0 ... 48 A	0 ... 18 A
	R4	-	-	0 ... 180 A	0 ... 120 A	-	-
Resistance ranges	R1	6.25 Ω ... 10 kΩ	16.7 Ω ... 53.7 kΩ	11.2 Ω ... 4.77 kΩ	16.7 Ω ... 10.7 kΩ	4.17 Ω ... 6.72 kΩ	11.2 Ω ... 47.7 kΩ
	R2	0.63 Ω ... 1.01 kΩ	1.67 Ω ... 5.37 kΩ	1.12 Ω ... 477 Ω	1.67 Ω ... 1.07 kΩ	0.42 Ω ... 672 Ω	1.12 Ω ... 4.77 kΩ
	R3	0.063 Ω ... 100 Ω	0.167 Ω ... 537 Ω	0.112 Ω ... 47.7 Ω	0.167 Ω ... 107 Ω	0.042 Ω ... 67.2 Ω	0.112 Ω ... 477 Ω
	R4	-	-	0.012 Ω ... 4.77 Ω	0.017 Ω ... 10.7 Ω	-	-
Power ranges ²⁾ continuous/short-time	R1	0 ... 96 W/96 W	0 ... 96 W/96 W	0 ... 14.4 W/14.4 W	0 ... 14.4 W/14.4 W	0 ... 144 W/144 W	0 ... 144 W/144 W
	R2	0 ... 600 W/600 W	0 ... 600 W/600 W	0 ... 144 W/144 W	0 ... 144 W/144 W	0 ... 900 W/900 W	0 ... 900 W/900 W
	R3	0 ... 1000 W/1500 W	0 ... 1000 W/1000 W	0 ... 600 W/600 W	0 ... 600 W/600 W	0 ... 1500 W/2250 W	0 ... 1500 W/1500 W
	R4	-	-	0 ... 1500 W/3000 W	0 ... 1500 W/3000 W	-	-
Rise/fall time ³⁾		30 μs	30 μs	30 μs	30 μs	30 μs	30 μs
Input capacity ca.		2 μF	2 μF	2 μF	2 μF	2 μF	2 μF
Load terminals ⁴⁾ rear / front		BPK4-60L / -	BPK4-30L / -	FKS20/5-SM8 with safety cover / -	FKS20/5-SM8 with safety cover / -	BPK4-60L / -	BPK4-30L / -
Mains voltage ⁵⁾		1/N/PE AC 230 V 50 ... 60 Hz	1/N/PE AC 230 V 50 ... 60 Hz	1/N/PE AC 230 V 50 ... 60 Hz	1/N/PE AC 230 V 50 ... 60 Hz	1/N/PE AC 230 V 50 ... 60 Hz	1/N/PE AC 230 V 50 ... 60 Hz
Mains voltage toggleable ⁵⁾		1/N/PE AC 115 V 50 ... 60 Hz	1/N/PE AC 115 V 50 ... 60 Hz	1/N/PE AC 115 V 50 ... 60 Hz	1/N/PE AC 115 V 50 ... 60 Hz	1/N/PE AC 115 V 50 ... 60 Hz	1/N/PE AC 115 V 50 ... 60 Hz
Power consumption		55 VA	55 VA	75 VA	75 VA	75 VA	75 VA
Noise max. ⁵⁾		57 dB(A)	57 dB(A)	60 dB(A)	60 dB(A)	60 dB(A)	60 dB(A)
Weight ca.		15 kg	15 kg	17.5 kg	17.5 kg	17.5 kg	17.5 kg
Housing / 3D model ⁶⁾		19", 2 U / PLI_M8	19", 2 U / PLI_M7	19", 2 U / PLI_M6	19", 2 U / PLI_M6	19", 2 U / PLI_M8	19", 2 U / PLI_M7

1. Minimum voltage for maximum static load current, linear derating to 0 V.
2. Level and duration of short-time power see diagram in technical data at page 53. The setting range reaches up to the short-time power.
3. Rise and fall times are defined from 10 ... 90 % and 90 ... 10 % of maximum current at "fast" regulation speed (constant current mode, tolerance ±20 %). Rise and fall time in „medium“ regulation speed: ca. 150 μs, „slow“: ca. 2 ms.
4. Description of available terminals starting at page 109.
5. Mains voltage tolerance: ±10 %.
6. Measured at the front in distance of 1 m.
7. 1 U = 44.45 mm. Detailed dimensions by means of 3D models at www.hoechert-hackl.com/downloads.

Options (Summary) and Accessories

Order number	Article	Description
52-200-001-17	PLI02	GPIB interface
56-003-000-17	PLI21	MPPT function with unlock code
67-004-030-17	K-RS-SNM 9-9	RS-232 cable (nullmodem cable) PLI series
53-100-006-17	PLI06-N	Galvanically isolated I/O port instead of standard I/O port
53-100-005-17	PLI06	Galvanically isolated I/O port for retrofitting of existing device
64-303-000-17	PLI10	19" installation kit for 1 device with ½ 19", 2 U
64-304-000-17	PLI11	19" installation kit for 2 devices with ½ 19", 2 U
64-305-000-17	PLI12	19" installation kit for 1 device with 19", 2 U
64-306-000-17	PLI13	19" installation kit for 1 device with 19", 3 U
64-400-000-17	PLI14	Castors for devices starting at 5 U (1 set = 4 devices)
54-500-001-17	PLI16-06	Charger Starter Interface (CSI) for 60 V models
54-500-002-17	PLI16-12	Charger Starter Interface (CSI) for 120 V models
63-000-001-17	PLI17	Switch box external load activation via I/O port
66-001-000-17	PLI18	12 VDC mains supply, reverse polarity protection, 4 mm pole terminals (only for PLI14xx)
66-002-000-17	PLI19	12 VDC mains supply, 4 mm pole terminals (only for PLI32xx), 5 U height
65-002-000-17	FCC-PLIxx	Factory Calibration Certificate
64-409-000-17	SAB-PLI-2	Additional safety cover for load terminals for devices with 2 U (Note: cannot be reordered since the copper bar feed-through must be changed)
64-407-000-17	SAB-PLI-3B	Additional safety cover for load terminals for devices with 3 U (production series B)
64-403-000-17	SAB-PLI-5	Additional safety cover for load terminals for devices with 5 U
67-008-020-17	K-MS-PLI+K-MS-CAN	Cable set Master-Slave, consisting of K-MS-PLI and K-MS-CAN (each 2 m)
67-036-020-17	K-MS-PLI	Master-Slave cable I/O port (2 m)
67-037-020-17	K-MS-CAN	Master-Slave cable CAN (2 m)
63-000-002-17	SubD25 Doubler	Adapter 1x Sub-D 25 male connector to 2x Sub-D 25 female connector for I/O port PLI series
49-001-000-17	SX	Modified setting range for PLI Serie only after consulting H&H
49-002-000-17	SSX	Customized setting range only after consulting H&H
		Load cables see starting at page 113



PLI6xx

PLI14xx
PLI21xx

Operating modes		
Basic operating modes	CC, CV, CR, CP	
Combined operating modes	CC+CV, CR+CC+CV, CP+CC+CV, CV+CC	
Accuracy of setting		
	of setting	of corresponding range
Voltage	±0.2 %	±0.05 %
Current	±0.2 %	±0.05 %
Resistance (at 5 % to 100 % of voltage range)	±1.4 %	±0.3 % of current range
Power (at V and I > 30 % of range) (at V or I < 30 % of range)	±0.35 % ±0.7 %	±0.1 % ±0.25 %
Resolution	14 bits	
Accuracy of adjustable protections		
	of setting	of corresponding range
Overcurrent protection	±1.4 %	±0.3 %
Undervoltage protection	±1.4 %	±0.3 %
Resolution	12 bits	
Accuracy of measurement slow		
	of measured value (real value)	of corresponding range
Voltage	±0.01 %	±0.005 %
Current	±0.2 %	±0.05 %
Resistance	is calculated from current and voltage	
Power	is calculated from current and voltage	
Resolution	23 bits	
Sampling rate	250 ms, not triggerable	
Accuracy of display		
Number of decimal places	5	
Accuracy	Accuracy of measurement slow ±1 digit of the display value	
Accuracy of measurement fast		
	of measured value (real value)	of corresponding range
Voltage	±0.1 %	±0.05 %
Current	±0.2 %	±0.1 %
Resistance	calculated from voltage and current values	
Power	calculated from voltage and current values	
Resolution	16 Bit	
Sampling rate	200 µs ... 1000 s	
Accuracy of trigger voltage and current measurement		
Voltage	±1 % of range	
Current	±1 % of range	
Dynamic function (LIST)		
No. of load levels	max. 300, with ramp and dwell time setting	
	min.	max.
Dwell time	200 µs	1000 s
Ramp time	0 s	1000 s
Resolution	200 µs	
Accuracy of the setting times	±0.02 %	
Delay at triggered start	max. 300 µs	

Data acquisition		
to external USB flash drive		
Sampling rate	0.5 to 30 s, resolution 0.1 s	
Measurement data	timestamp, voltage, current	
No. of measurement points	limited by USB memory capacity	
File format	.csv	
to internal memory		
Sampling rate	200 µs ... 1000 s, resolution 200 µs, synchronized with dynamic function	
Measurement data	timestamp, voltage, current	
No. of measurement points	max. 40,000	
Settings memories		
No. of user settings	9, selectable (incl. programmed list) 1 for last device settings at power-off or power fail	
I/O port: accuracy of analog control 0 ... 10 V		
	of setting	of corresponding range
Voltage	±0.2 %	±0.1 %
Current	±0.2 %	±0.1 %
Overcurrent protection	±1 %	±0.4 %
Undervoltage protection	±1 %	±0.4 %
	Input resistance of analog inputs >10 kΩ	
I/O port: accuracy of analog monitor outputs 0 ... 10 V		
	of analog signal of real value	offset voltage
Voltage	±0.2 %	±15 mV
Current	±0.2 %	±15 mV
	load capacity minimal 2 kΩ	
I/O port: permissible voltages		
	standard I/O port	isolated I/O port (option PLI06)
Vin-io (GND - neg. load input)	PLIxxxxZV: must be galvanically isolated all others: max. 2 V ¹⁾	PLIxxxxZV: max. 2 V ¹⁾ all others: max. 800 V ¹⁾
VioPE (GND - PE)	max. 125 V ¹⁾	max. 125 V ¹⁾
I/O port: control outputs and inputs		
Outputs	activation state load input (low active) status overload (OV, OCP, OPP, OTP, low active) trigger output (low active) programmable logic output (by SCPI command)	
Output level	selectable, 3.3 V, 5 V, 12 V or externally programmable up to 30 V	
Control inputs	activation state load input (low active) operating mode selection trigger input (high active) readable logic input (by SCPI command) control input (activates the analog signals, low active) remote shut-down (low active)	
input level	3 ... 30 V	

The specified accuracies refer to an ambient temperature of 23 ±5 °C. The specified accuracies are valid when the unit is connected to undisturbed voltages (ripple and noise < 0.1 %). At voltages with higher disturbance values the accuracy can change for the worse.

¹⁾ positive/negative DC voltage or RMS value of a sinusoidal AC voltage

Technical Data (continued)

Input		
Input resistance	> 50 kΩ when load input is off diode function at reverse polarity up to nominal current, except ZV models	
Input capacity	see model overview	
Parallel operation	up to 5 devices in Master-Slave operation	
Max. input voltage	see model overview	
Min. input voltage	see model overview	
Input: permissible voltages		
	standard I/O port	isolated I/O port (option PLI06)
Vin-PE (neg. load input - PE)	max. 125 V ¹⁾	PLIxxxZV: max. 125 V ¹⁾ all others: max. 800 V ¹⁾
Vin+PE (pos. load input - PE)	Vmax + max. 125 V ¹⁾	PLIxxxZV: Vmax + max. 125 V ¹⁾ all others: Vmax + max. 800 V ¹⁾
Power		
Continuous power	see model overview (at Ta = 21 °C)	
Derating	-1.2 %/°C for Ta > 21 °C	
Overload capability (short-time power)	see model overview The max. possible overload Po depends on the temperature of the device and therefore on the previously consumed continuous power Pd. The possible overload duration depends on the value of the overload Px.	
Protection and monitoring		
Protective devices	overcurrent overpower overtemperature	
Monitoring	overvoltage indication reverse polarity indication undervoltage indication (if the input voltage is too low for the set current)	
Terminals		
Load input	see model overview	
Sense	PH2/7.62-BU16, see starting at page 109	
Operating conditions		
Operating temperature	5 ... 40 °C	
Stock temperature	-25 ... 65 °C	
Max. operating height	2,000 m above sea level	
Pollution degree	2	
Overvoltage category of mains	II	
Max. humidity	80 % at 31 °C, linear decreasing to 50 % at 40 °C	
Min. distance rear panel to wall or other objects	70 cm	
Cooling	3-stage air cooling, up from 3200 W variably controlled	
Noise. weight	see model overview	
Mains voltage	see model overview	
Power consumption	see model overview	

Housing	
Color	
Front	RAL7035 (light grey)
Rear	stainless steel
Top, side panels	RAL7037 (dusty grey)
Safety and EMC	
Protection class	1
Protection	IP20
Measuring category	0 (CAT I according to EN61010:2004)
Electrical safety	DIN EN 61010-1 DIN EN 61010-2-030
EMC	DIN EN 61326-1 DIN EN 55011 DIN EN 61000-3-2 DIN EN 61000-3-3
Standard interfaces	
Data interfaces	RS-232, USB, LAN, CAN
I/O port	standard I/O port (not isolated)
Available options	
Data interfaces PLI02	GPIO
Mechanical options PLI10 PLI11 PLI12 PLI13 PLI14	19" installation kit for 1 device with ½ 19"; 2 U 19" installation kit for 2 devices with ½ 19"; 2 U 19" installation kit for 1 device with 19"; 2 U 19" installation kit for 1 device with 19"; 3 U heavy-load castors (5 U and upwards)
Function enhancement PLI21 Accuracy	MPPT function with activation code see accuracy of measurement fast
Hardware extensions PLI06	galvanically isolated I/O port
PLI16-06 PLI16-12 Accuracy Load current Activation Activation time	Charger Starter Interface (CSI) for 60 V models (6 ... 60 V) Charger Starter Interface (CSI) for 120V models (6 ... 120V) ±1 % ±200 mV max. 0.1 A can be coupled with activation state of load input 0.1 ... 100 s ±0.3 s
PLI17	switch box for external load activation via I/O port
DC mains supply PLI18 PLI19	12 V DC mains supply (only for PLI14xx) 12 V DC mains supply (only for PLI32xx with housing extension to 5 U, toggling by mains selection switch)
Calibration, warranty	
FCC-PLIxx	Factory Calibration Certificate, twice for free
Warranty	2 years

¹⁾ positive/negative DC voltage or RMS value of a sinusoidal AC voltage